



# A.175

SISTEMA DE BATENTE RPT

## CATÁLOGO TÉCNICO

---

**etrusal**<sup>®</sup>  
Alumínio com perfil humano.

**Casa da Galeria - Azores Art of Hosting**  
M-Arquitectos  
Ponta Delgada, Açores

**extrusal**<sup>®</sup>  
Alumínio com perfil humano.

# 01

## A.175

sistema de abrir RPT

junho . 2024 . r1





Extrusal

**SENSI Azores Nature & SPA**  
Arq. Luís Almeida e Sousa  
Ponta Delgada, Açores

# 01

## **DETALHE 3D**

sistema de abrir RPT

A.175

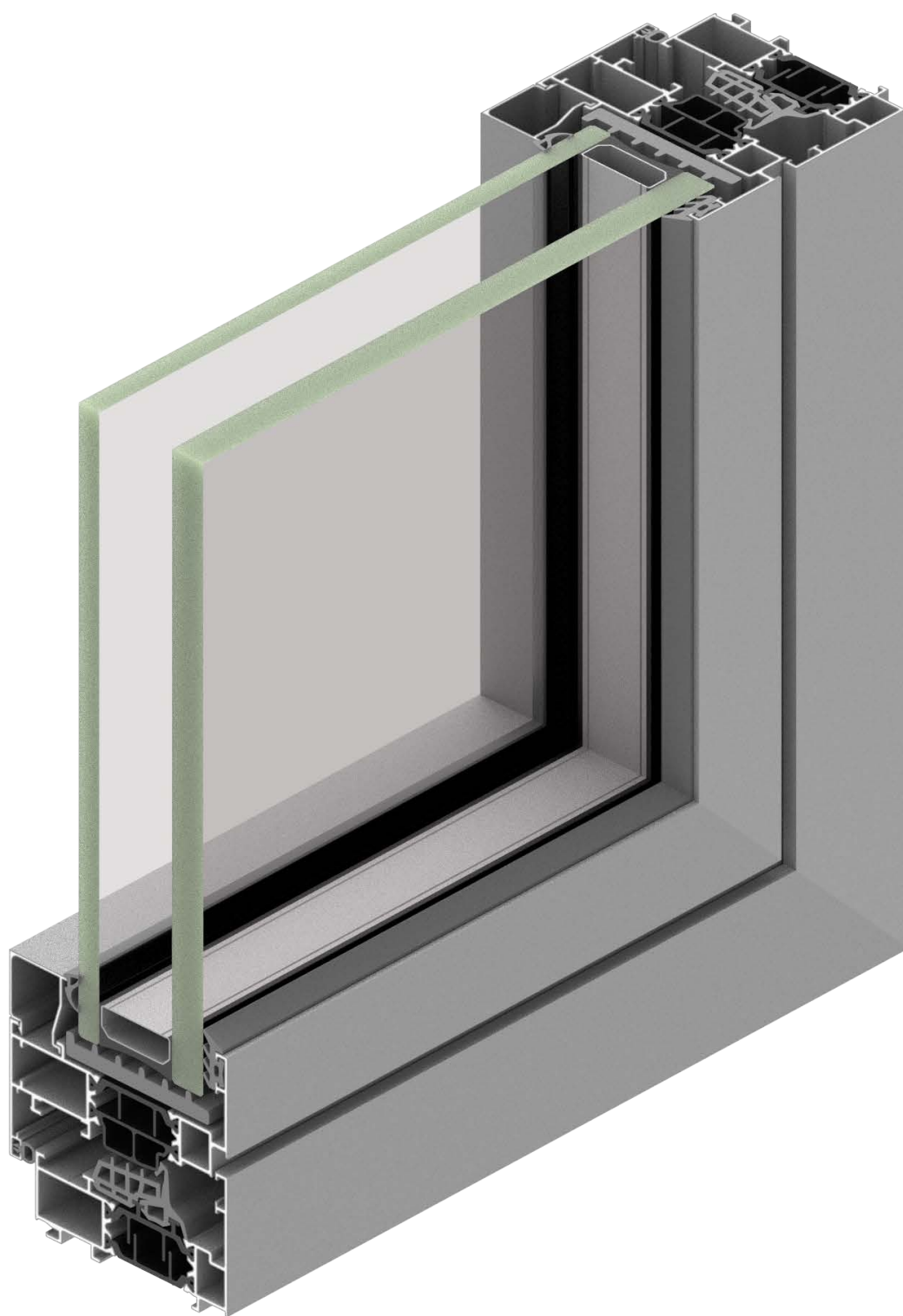

**Acessórios**  
152

**Instruções Montagem**  
144

**Instruções Fabrico**  
136

**Tipologias Construtivas**  
68

**Secções**  
46

**Perfis**  
18

**Características Técnicas**  
8

**Produto**  
6

# 02 **CARAC. TÉCNICAS**

sistema de abrir RPT

A.175



Aplicação

Construção Nova / Reabilitação



Tipologias Abertura

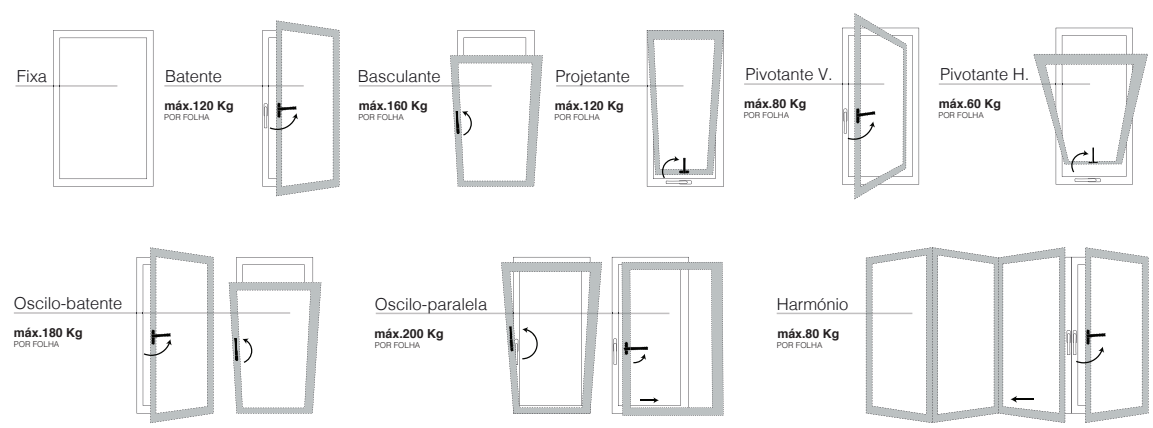

Peso máximo | folha

200 kg



Altura máxima | folha

2600 mm



Largura máxima | folha

1700 mm



Vista da folha

87,6 mm



Enchimento máximo

54 mm



Certificados  
Produto & Sistema Gestão Qualidade e Ambiente



Extrusal

**++** Desempenho Acústico

39 dB

**☒** Coeficiente Transmissão Térmica

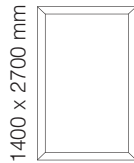

Vidro Ug  $0.9 \text{ W/m}^2\text{K}^{-1}$   
**1.3**  
EN ISO 10077-1

Vidro Ug	Janela Uw
$1.1 \text{ W/m}^2\text{K}^{-1}$	$1.5 \text{ W/m}^2\text{K}^{-1}$
$1.0 \text{ W/m}^2\text{K}^{-1}$	$1.4 \text{ W/m}^2\text{K}^{-1}$
$0.9 \text{ W/m}^2\text{K}^{-1}$	$1.3 \text{ W/m}^2\text{K}^{-1}$



**☐** Ensaio Tipo Inicial

**Permeabilidade ao ar**  
(pressão máx. ensaio / EN12207) Classe **4**

**Estanquidade à água**  
(EN12208) Classe **E1350**

**Resistência à ação do vento**  
(EN12210) Classe **C5**

**Boletim de ensaio: CXL 26/12. Organismo notificado nº 0856**  
Dimensão: 1600 mm x 2000 mm. Janela composta por duas folhas móveis, uma oscilo-batente e outra de batente.

**☐** Perfis Alumínio

**Liga EN-AW 6060**  
EN 573-3 | EN 755-2  
EPM T6

**PA 6.6 GF 25**  
25% fibra de vidro  
34 mm

Comprimento Nominal **6500 mm**  
Espessura Nominal **1.5 mm**











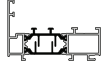

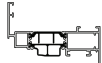

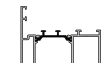



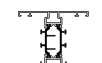

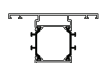



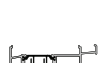



$R_{p0.2} \geq 120 \text{ MPa}$   
 $R_m \geq 160 \text{ MPa}$   
 $A_{50mm} \geq 6\%$

**☐** Tratamentos





























**Anodização - Acabamento Acetinado e Polido**  
Licença QUALANOD nº1402, desde 1983

**Lacagem - Acabamento mate | brilhante | acetinado | metalizado | Texturado**  
Licença QUALICOAT nº808, desde 1995

**Lacagem Decorativa**  
Efeito Madeira









Perfil	Ref.	Área Anod.	Polir	Inércia Ixx	Iyy	Pág.	Perfil	Ref.	Área Anod.	Polir	Inércia Ixx	Iyy	Pág.
	A.175.010	36,39	7,80	4,92	28,73	20		A.175.170	39,55	11,75	14,79	43,37	32
	A.175.020	43,28	10,30	7,43	42,93	24		A.175.200	50,10	14,35	27,12	49,32	22
	A.175.040	44,29	11,25	21,02	43,09	20		A.175.210	41,44	15,30	40,96	41,12	43
	A.175.050	51,24	14,25	26,46	65,98	24		A.175.260	66,35	31,65	334,67	51,21	30
	A.175.060	42,66	10,80	34,96	9,42	28		A.175.270	43,07	10,30	7,45	34,04	22
	A.175.070	50,55	14,65	47,94	28,05	28		A.175.280	47,16	13,15	27,43	72,00	23
	A.175.080	60,35	25,65	204,03	44,69	29		A.175.300	45,02	10,35	8,84	44,42	26
	A.175.090	31,25	7,30	1,76	33,28	42		A.175.310	52,94	14,30	29,26	67,28	26
	A.175.100	50,79	14,65	29,59	69,86	25		A.175.320	49,09	14,65	28,24	59,17	27
	A.175.120	50,64	14,20	26,70	65,33	25		A.175.330	50,66	20,00	26,13	78,18	43
	A.175.130	51,79	45,60	27,77	59,80	31		A.175.340	40,45	10,30	33,13	7,63	27
	A.175.140	35,10	7,80	4,10	28,98	31		A.175.350	41,89	10,75	8,13	34,09	23
	A.175.150	39,34	7,80	5,27	31,24	21		A.175.360	34,82	4,45	1,22	30,40	42
	A.175.160	34,58	6,00	4,65	25,76	21		A.175.910	36,39	7,80	4,92	28,73	32

Unidades: Área Anodização (dm<sup>2</sup>/m)  
Área Polimento (dm<sup>2</sup>/m)  
Inércia (cm<sup>4</sup>)

Perfil	Ref.	Área		Inércia		Pág.	Perfil	Ref.	Área		Inércia		Pág.
		Anod.	Polir	lxx	lyy				Anod.	Polir	lxx	lyy	
	A.175.930	51,79	15,60	27,77	59,71	33		F.009.139	8,70	1,80	-	-	44
	A.055.015	19,08	2,60	-	-	44		F.009.155	18,21	7,20	1,11	2,57	39
	A.055.090	39,07	22,60	155,82	19,80	34		F.009.156	26,20	10,20	1,28	11,66	39
	A.055.110	22,56	13,20	3,80	29,52	35		F.009.157	30,20	12,20	1,34	22,27	39
	A.080.029	25,73	-	33,67	19,29	35		F.010.140	12,07	3,60	-	-	44
	A.100.013	5,24	1,50	-	-	44		A.040.004	17,88	5,45	-	-	40
	A.100.023	12,48	1,80	-	-	44		A.040.025	14,54	3,85	-	-	40
	B.055.580	27,98	14,40	1,36	29,06	36		A.040.026	15,84	4,50	-	-	40
	B.095.080	27,98	14,40	1,38	49,54	36		A.040.039	14,12	3,45	-	-	40
	B.150.030	41,84	26,20	4,52	115,03	36		A.040.048	8,30	2,70	-	-	44
	F.009.135	33,54	15,50	1,41	38,65	37		A.040.050	14,94	4,05	-	-	40
	F.009.136	49,00	18,00	0,63	121,44	38		A.040.069	9,81	2,75	-	-	40
	F.009.137	23,75	11,50	7,65	8,35	37		A.040.070	10,21	2,95	-	-	40
	F.009.138	14,07	6,60	1,05	1,13	37		A.040.107	16,55	4,85	-	-	40

Unidades: Área Anodização (dm<sup>2</sup>/m)  
Área Polimento (dm<sup>2</sup>/m)  
Inércia (cm<sup>4</sup>)



Perfil	Ref.	Área Anod.	Polir	Inércia lxx	lyy	Pág.	Perfil	Ref.	Área Anod.	Polir	Inércia lxx	lyy	Pág.
	<b>A.040.110</b>	17,65	5,00	-	-	<b>40</b>		<b>A.040.143</b>	16,19	4,65	-	-	<b>41</b>
	<b>A.040.133</b>	19,92	6,25	-	-	<b>41</b>		<b>A.040.144</b>	17,97	5,25	-	-	<b>41</b>
	<b>A.040.140</b>	10,63	3,15	-	-	<b>41</b>		<b>A.040.146</b>	19,86	6,25	-	-	<b>41</b>
	<b>A.040.141</b>	14,65	3,65	-	-	<b>41</b>		<b>A.040.147</b>	19,01	5,85	-	-	<b>41</b>
	<b>A.040.142</b>	15,33	4,25	-	-	<b>41</b>							

Unidades: Área Anodização (dm<sup>2</sup>/m)  
Área Polimento (dm<sup>2</sup>/m)  
Inércia (cm<sup>4</sup>)

**Produto**  
6

**Características Técnicas**  
8

**Perfis**  
18

**Seções**  
46

**Tipologias Construtivas**  
68

**Instruções Fabrico**  
136

**Instruções Montagem**  
144

**Acessórios**  
152

# COEFICIENTE TRANSMISSÃO TÉRMICA

A.175

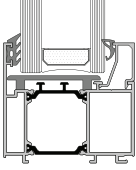
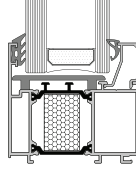
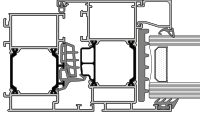
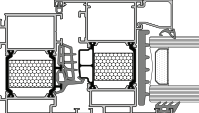
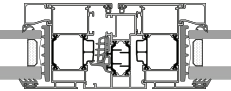
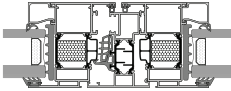
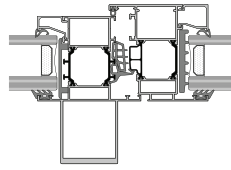
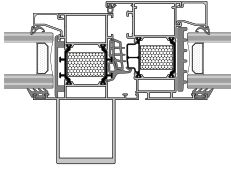
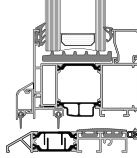
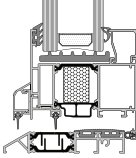
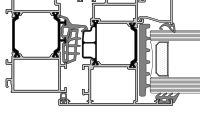
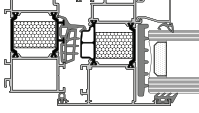
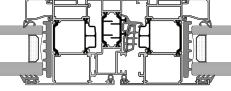
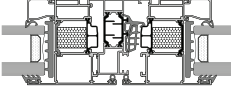
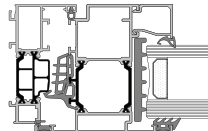
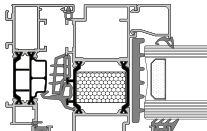
Corte Construtivo	Ref.	Coef. Trans. Térmica	Corte Construtivo	Ref.	Coef. Trans. Térmica
	A.175.040	<b>2,31</b>		A.175.040	<b>1,54</b>
	A.175.040 A.175.050	<b>2,23</b>		A.175.040 A.175.050	<b>1,42</b>
	A.175.050 A.175.340	<b>2,24</b>		A.175.050 A.175.340	<b>1,61</b>
	A.175.050 A.175.080	<b>2,36</b>		A.175.050 A.175.080 A.175.340	<b>1,52</b>
	A.100.023 A.175.050 A.175.360	<b>2,61</b>		A.100.023 A.175.050 A.175.360	<b>2,07</b>
	A.175.040 A.175.120	<b>2,35</b>		A.175.040 A.175.120	<b>1,45</b>
	A.175.120 A.175.340	<b>2,24</b>		A.175.120 A.175.340	<b>1,64</b>
	A.175.130 A.175.140	<b>2,18</b>		A.175.130 A.175.140	<b>1,57</b>

Unidades: (Wm<sup>2</sup>/K)

Radiosity Method ISO 10077-2 : 2017 - FLIXO 18 PRO®

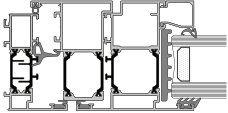
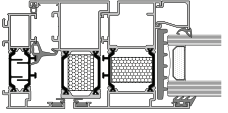
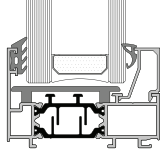
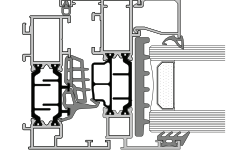
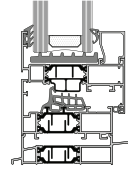
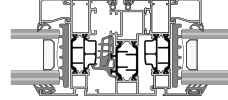
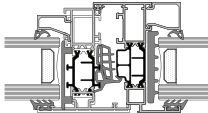
Corte Construtivo	Ref.	Coef. Trans. Térmica	Corte Construtivo	Ref.	Coef. Trans. Térmica
	A.175.170 A.175.910 A.175.930	<b>2,40</b>		A.175.170 A.175.910 A.175.930	<b>1,79</b>
	A.175.010	<b>2,01</b>		A.175.010 A.175.020	<b>1,86</b>
	A.175.010 A.175.020 A.175.090	<b>2,31</b>		A.175.020 A.175.340	<b>1,88</b>
	A.175.060 A.175.020	<b>1,84</b>			

Unidades: (Wm<sup>2</sup>K)

Radiosity Method ISO 10077-2 : 2017 - FLIXO 18 PRO®

Produto  
6

Características Técnicas  
8

Perfis  
18

Seções  
46

Tipologias Construtivas  
68

Instruções Fabrico  
136

Instruções Montagem  
144

Acessórios  
152

# PERFIL ENVIDRAÇAMENTO

A.175

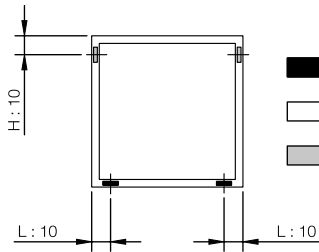
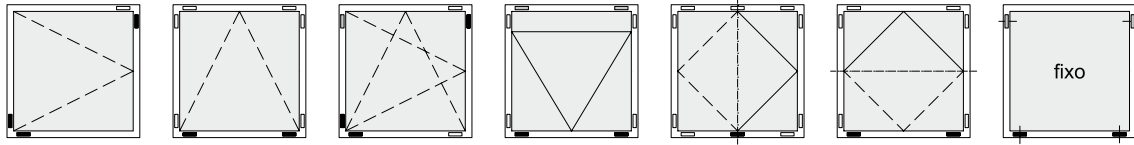

- Calço de Apoio
- Calço Periférico
- Calço Periférico de Segurança

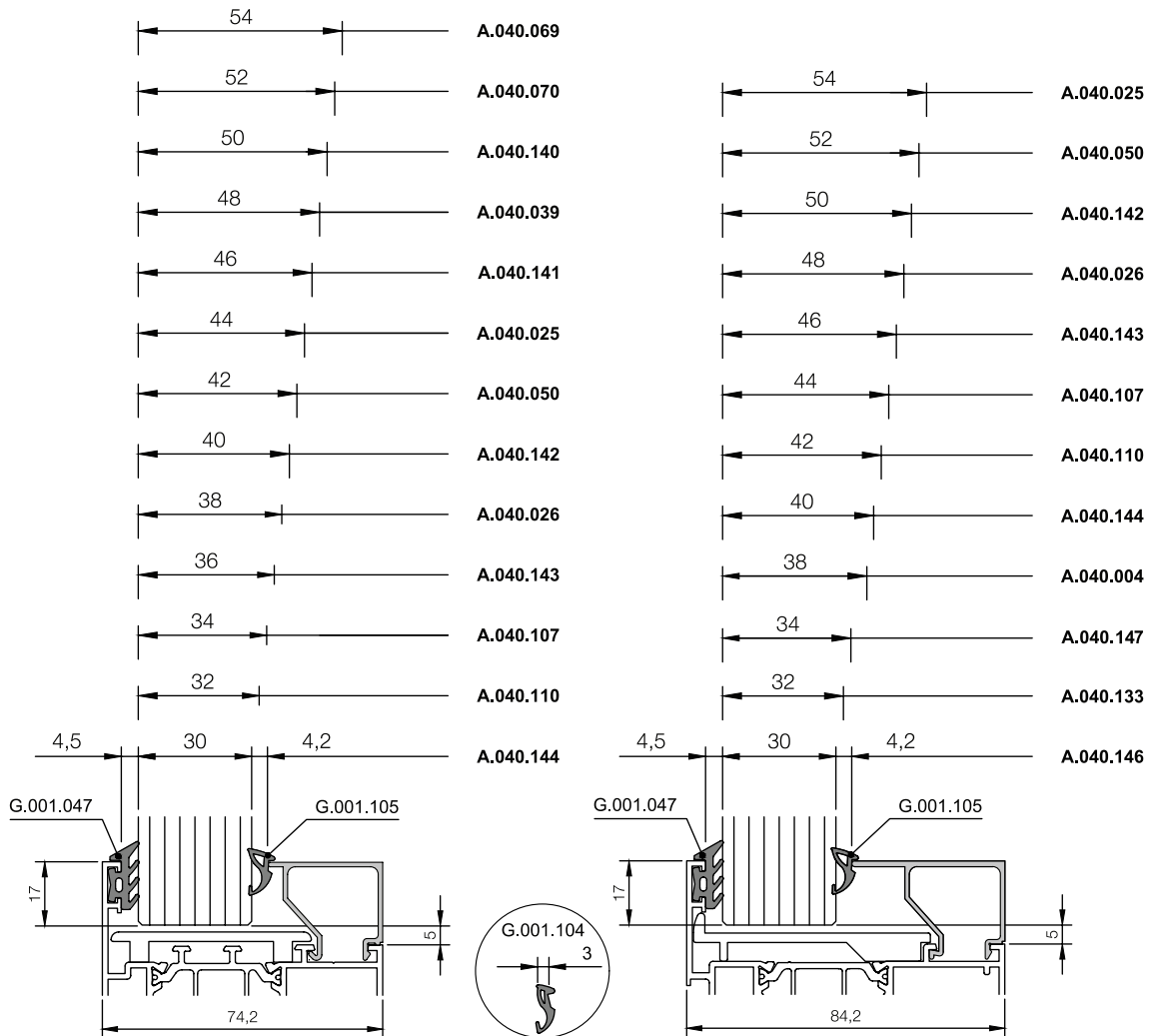
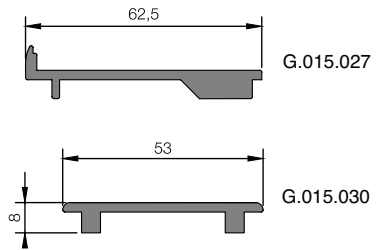

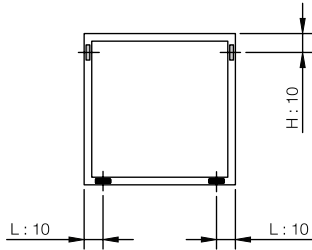
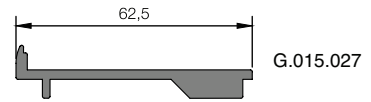
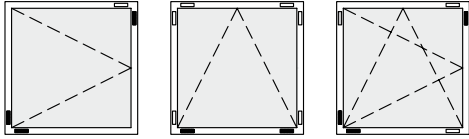

- Calço de Apoio
- Calço Periférico
- Calço Periférico de Segurança

- 54 A.040.140
- 52 A.040.039
- 50 A.040.141
- 48 A.040.025
- 46 A.040.050
- 4 A.040.142
- 42 A.040.026
- 40 A.040.143
- 38 A.040.107
- 36 A.040.110
- 34 A.040.144
- 4,5 32 4,2 A.040.004

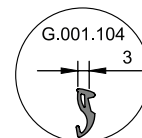
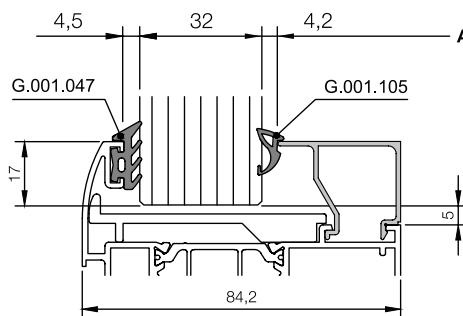

Produto  
6

Características Técnicas  
8

Perfis  
18

Seções  
46

Tipologias Construtivas  
68

Instruções Fabrico  
136

Instruções Montagem  
144

Acessórios  
152

# 03

## PERFIS

sistema de abrir RPT

A.175

## **Aro Fixo**

20

## **Aro Móvel**

24

## **Travessa**

28

## **Montante**

29

## **Projetante**

31

## **Pivotante**

32

## **Ligação**

34

## **Capeamento**

37

## **Bite**

40

## **Diverso**

42

**A.175.010**

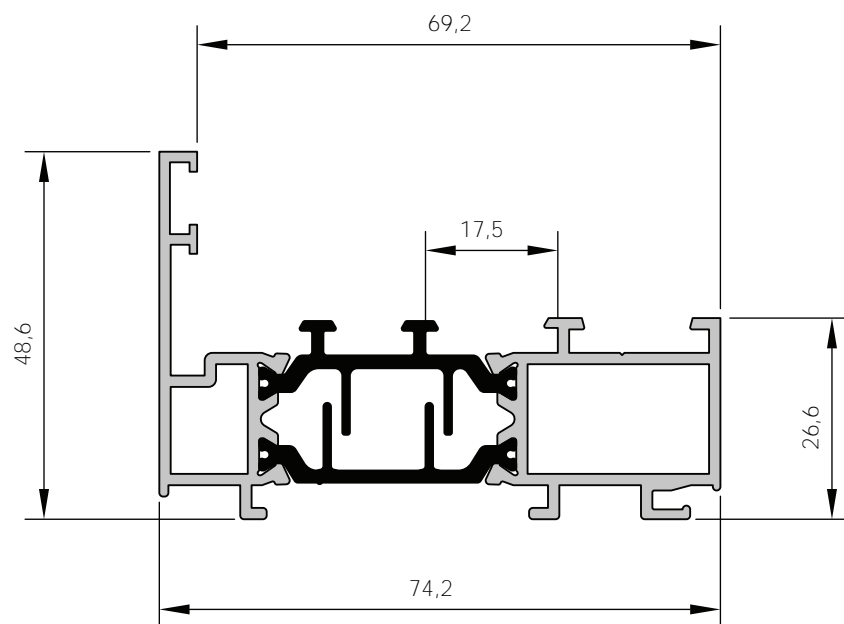

**A.175.040**

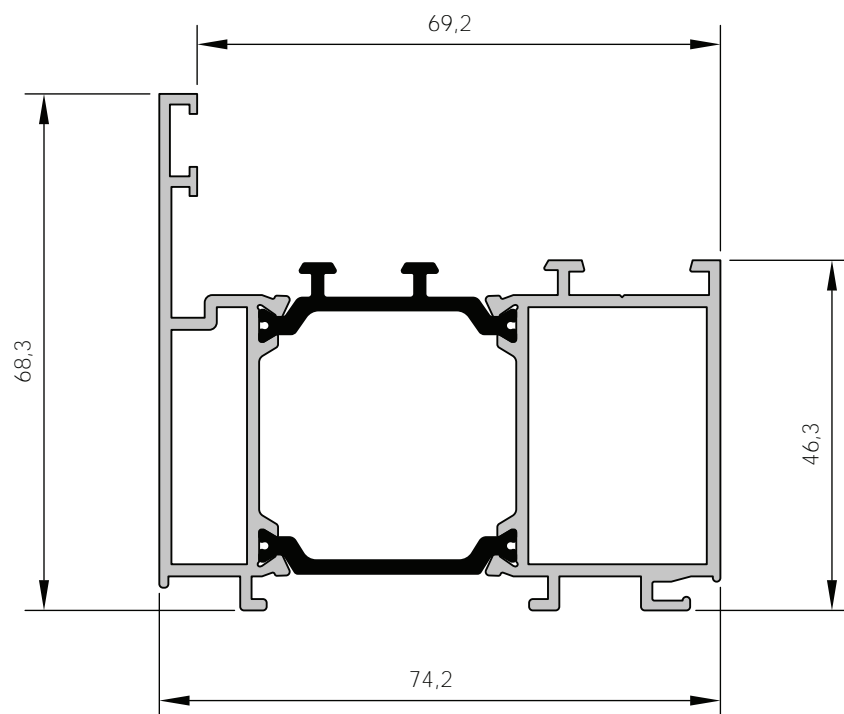

Escala 1:1



## A.175.150

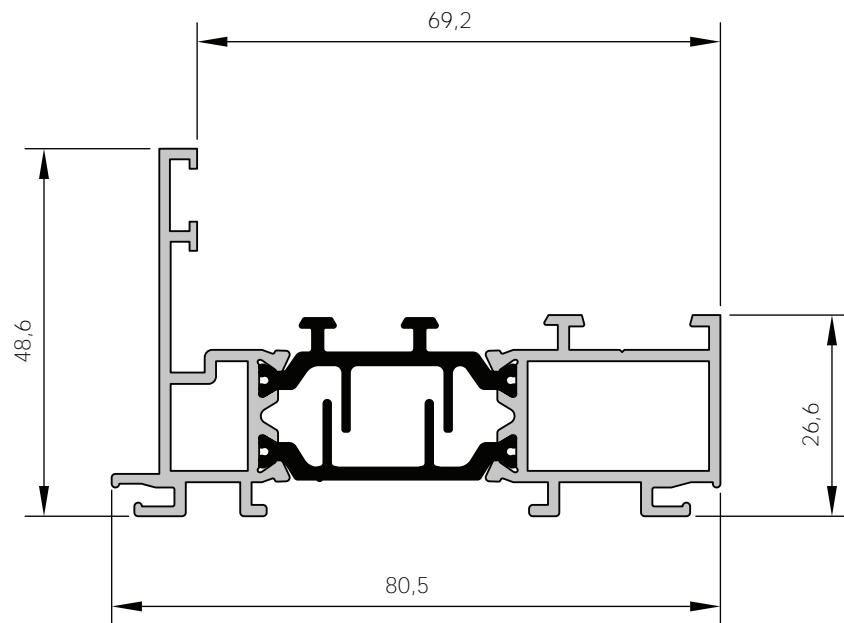

## A.175.160

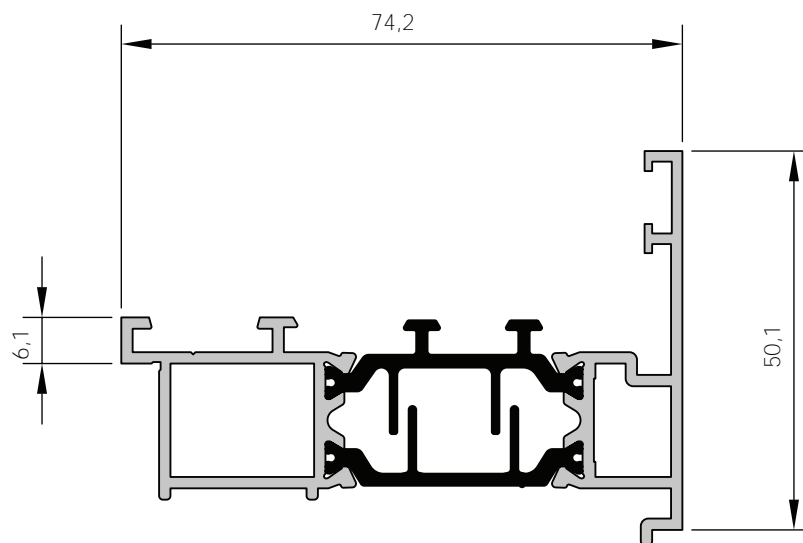

Escala 1:1

**A.175.200**

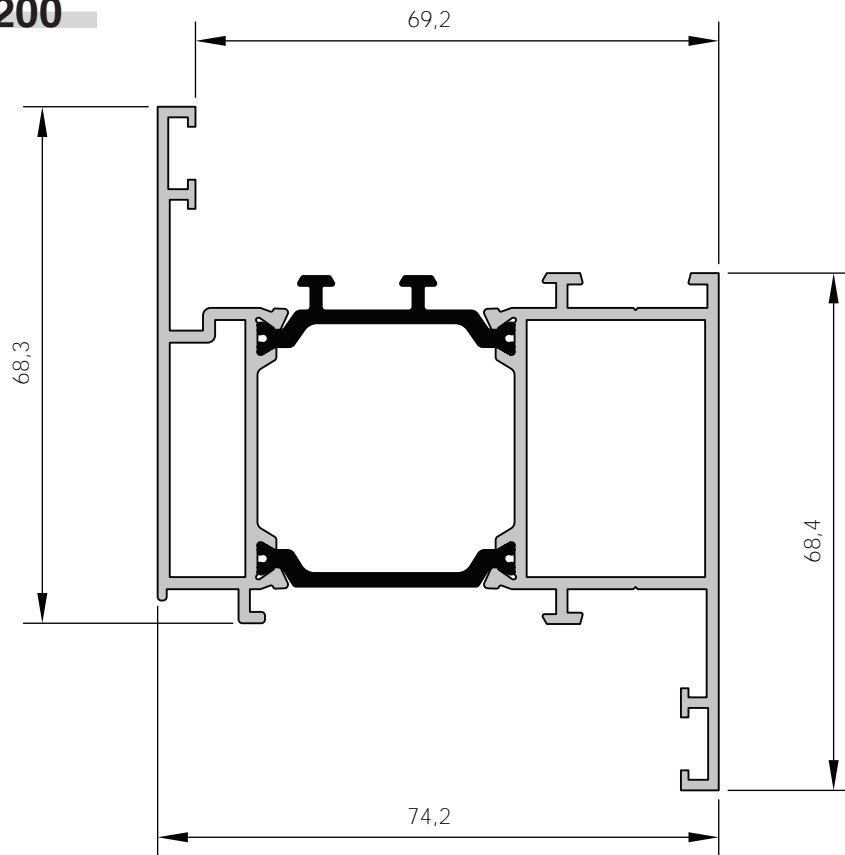

**A.175.270**

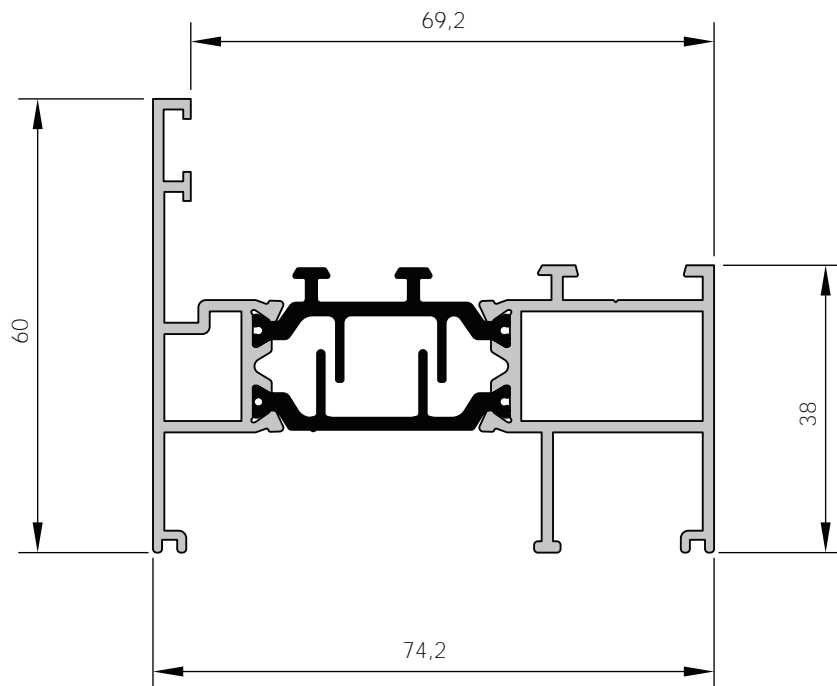

Escala 1:1

**A.175.280**

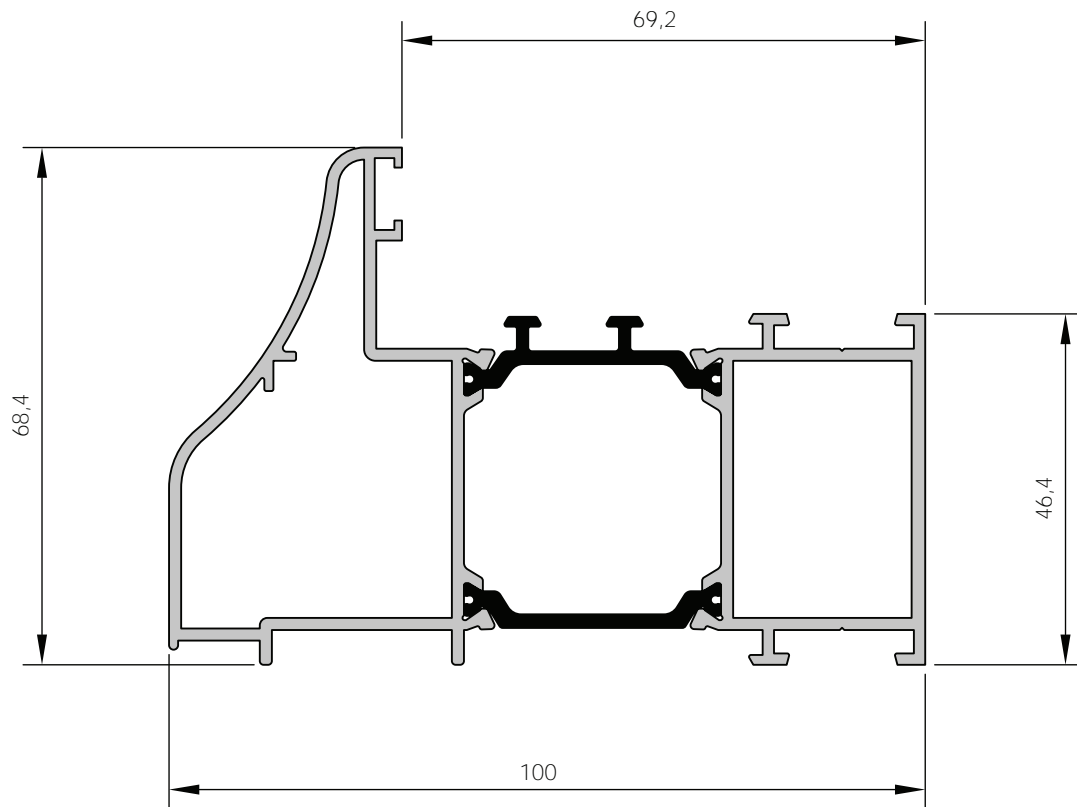

**A.175.350**

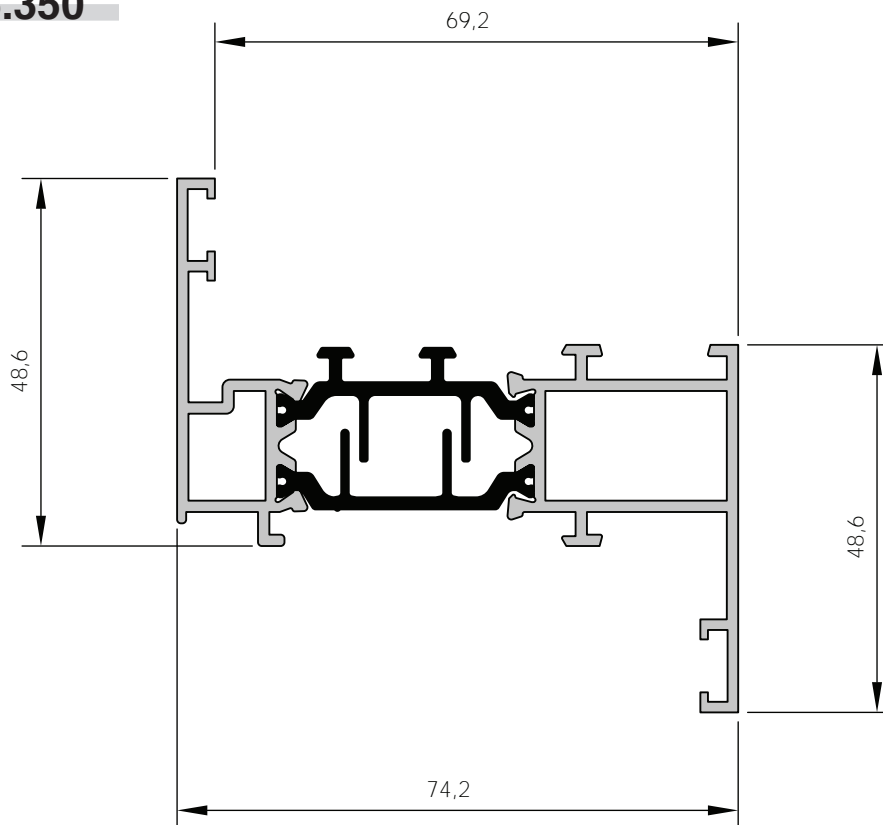

Escala 1:1

**A.175.020**

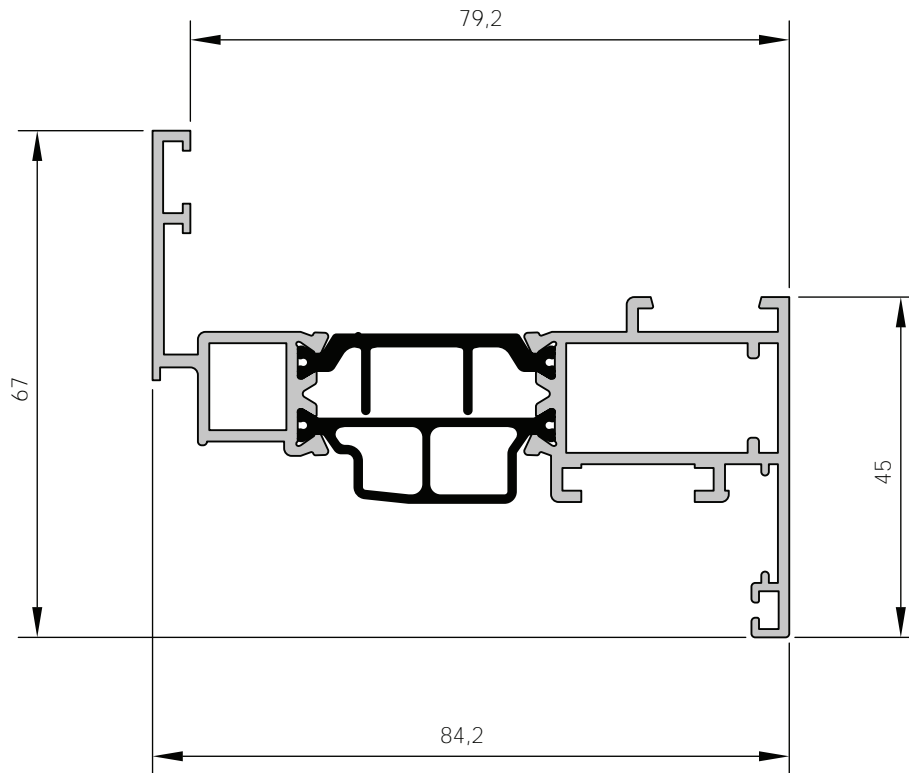

**A.175.050**

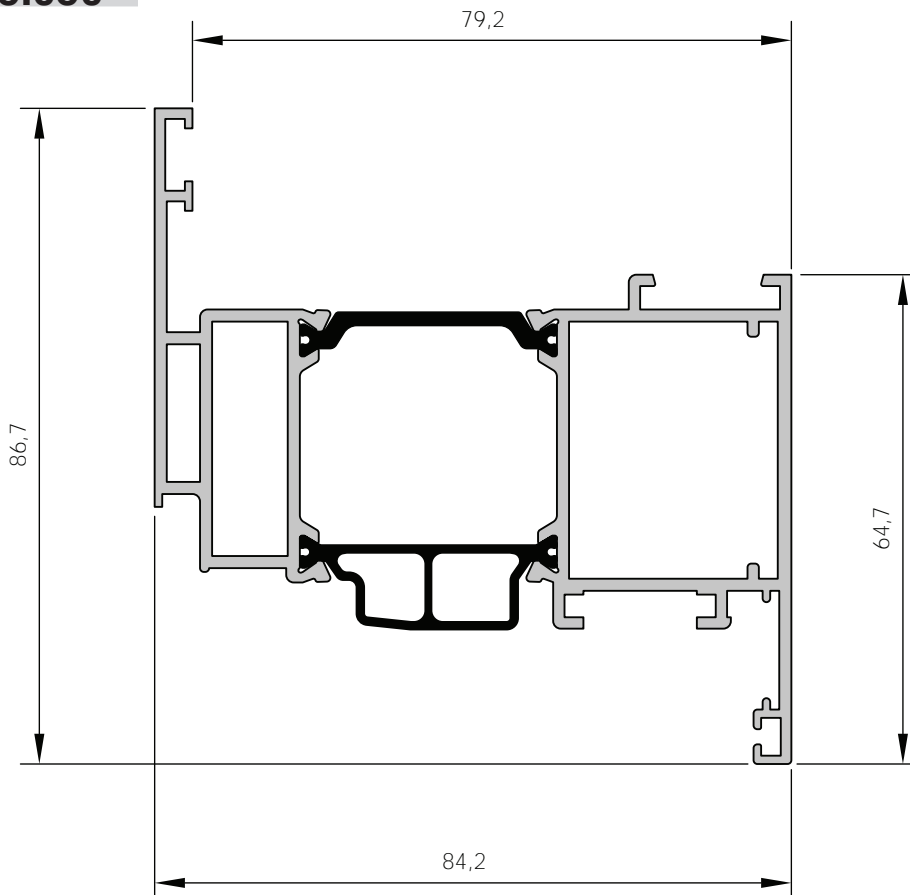

Escala 1:1

**A.175.100**

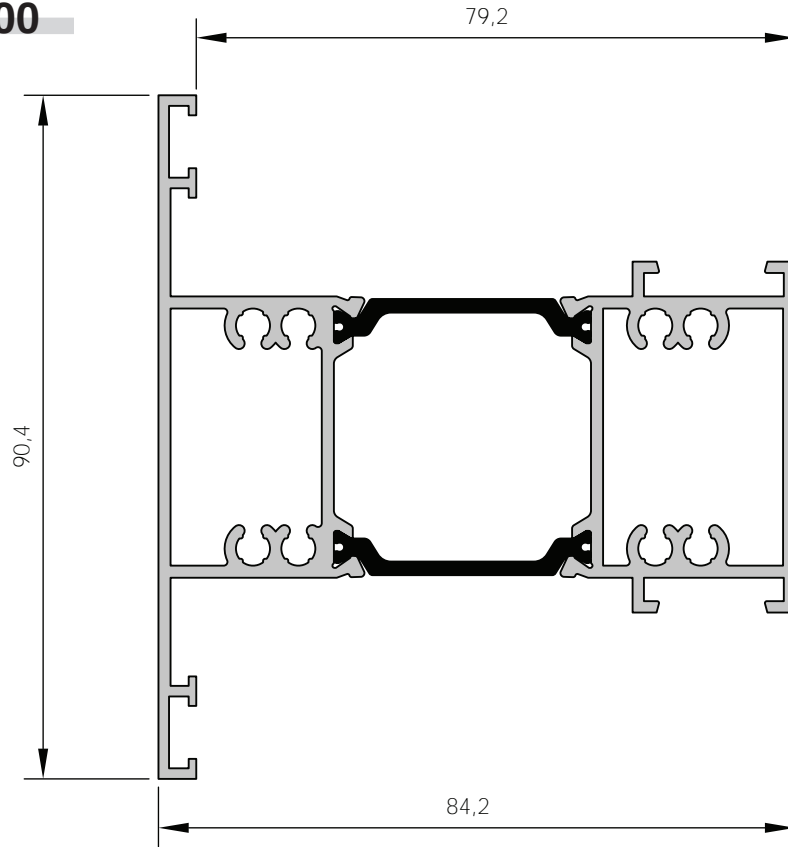

**A.175.120**

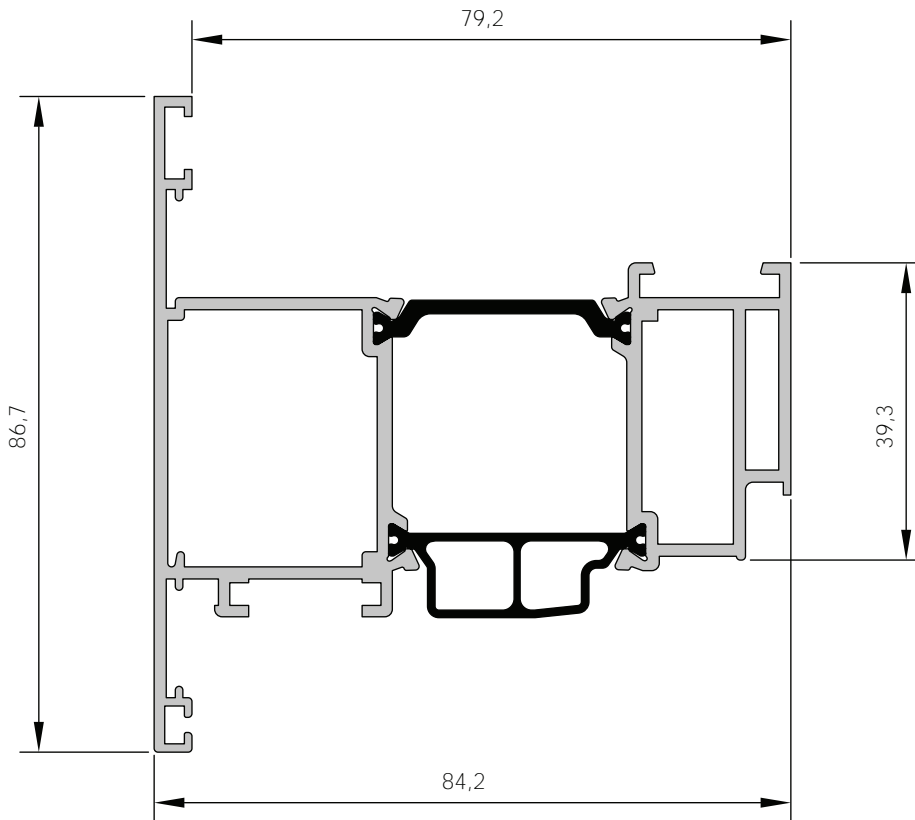

Escala 1:1

**A.175.300**

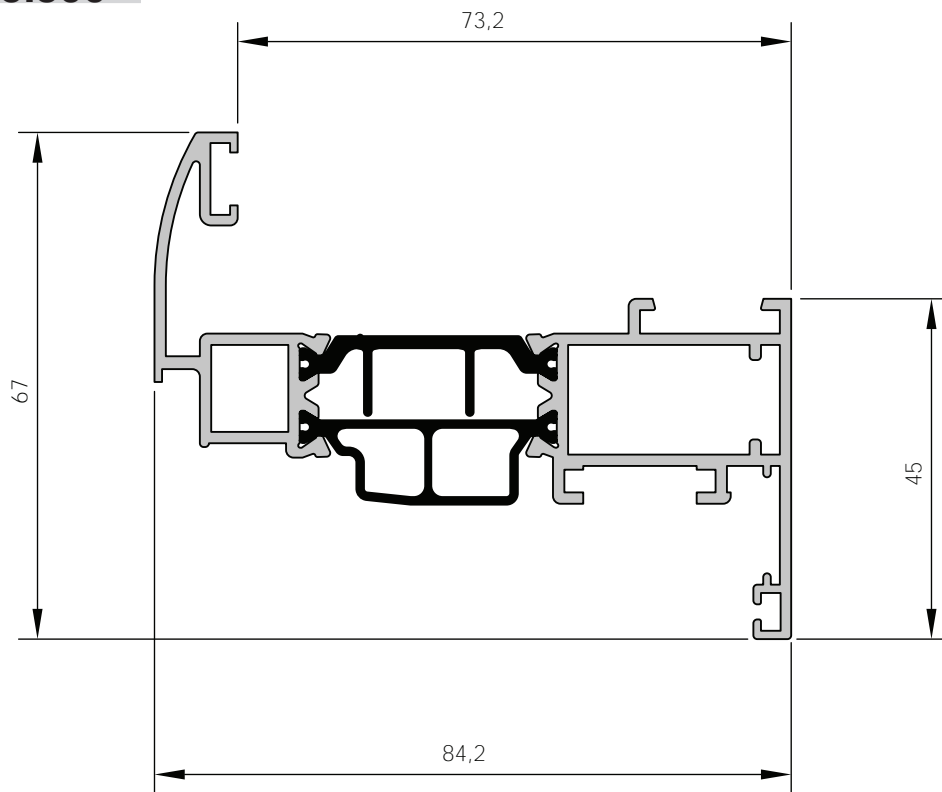

**A.175.310**

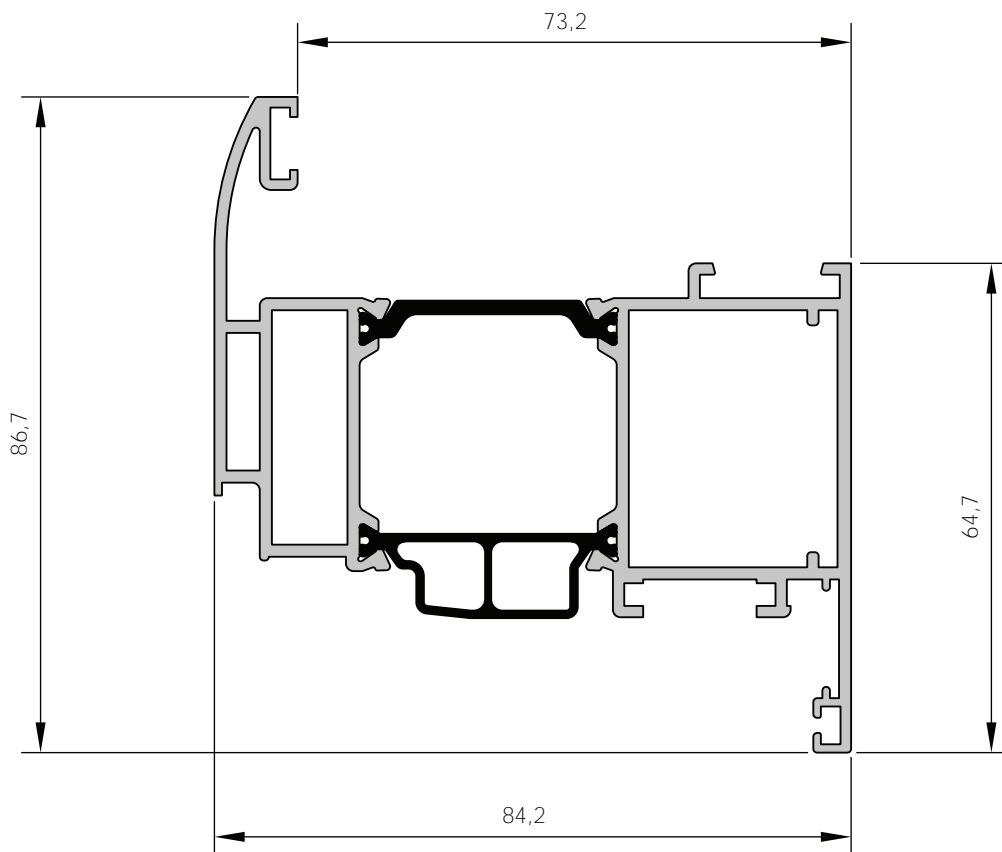

Escala 1:1

**A.175.320**

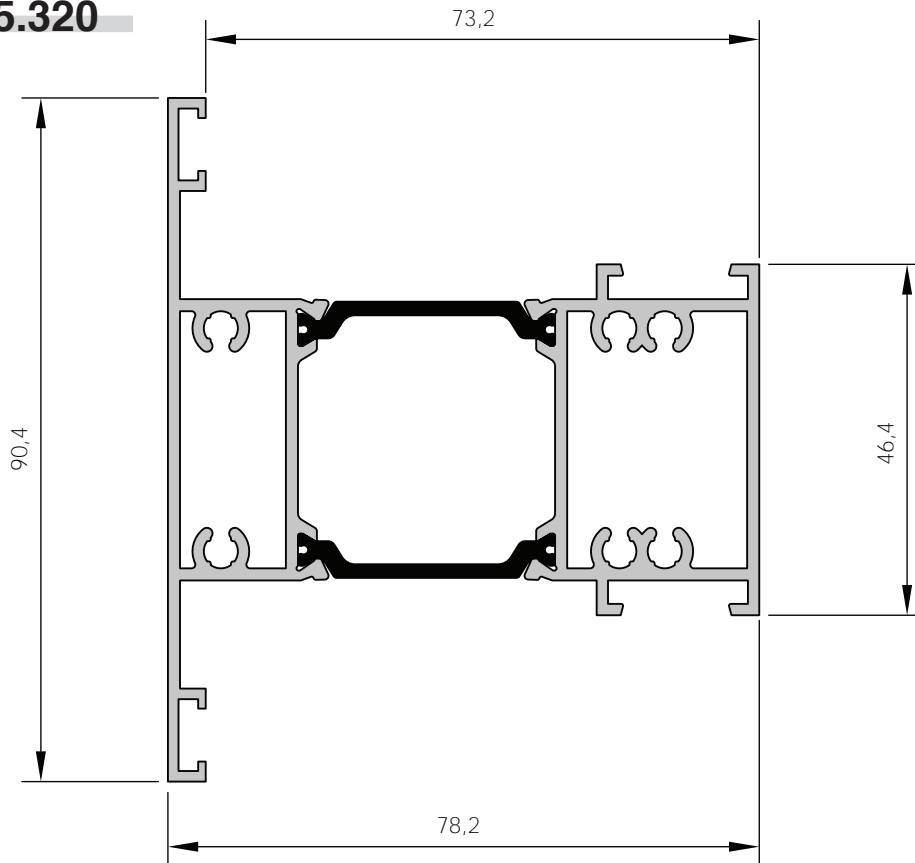

**A.175.340**

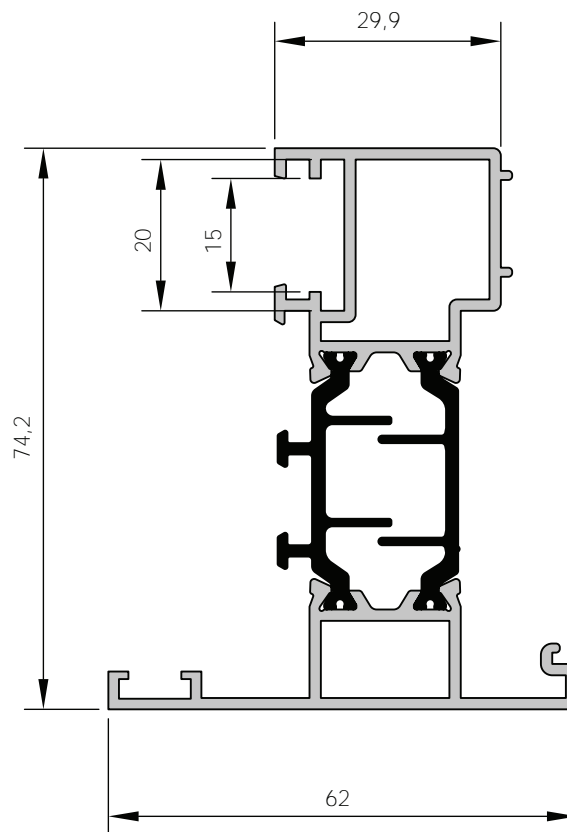

Escala 1:1

**A.175.060**

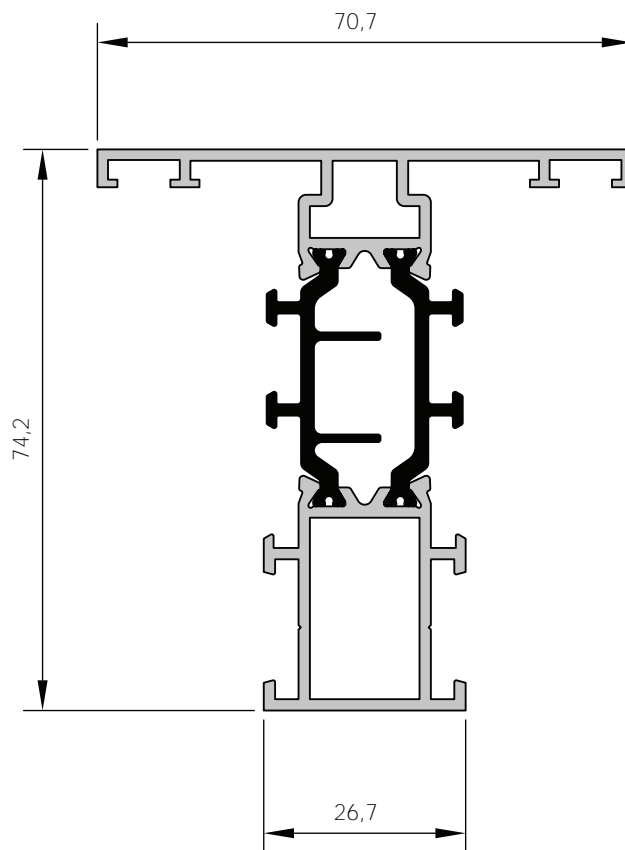

**A.175.070**

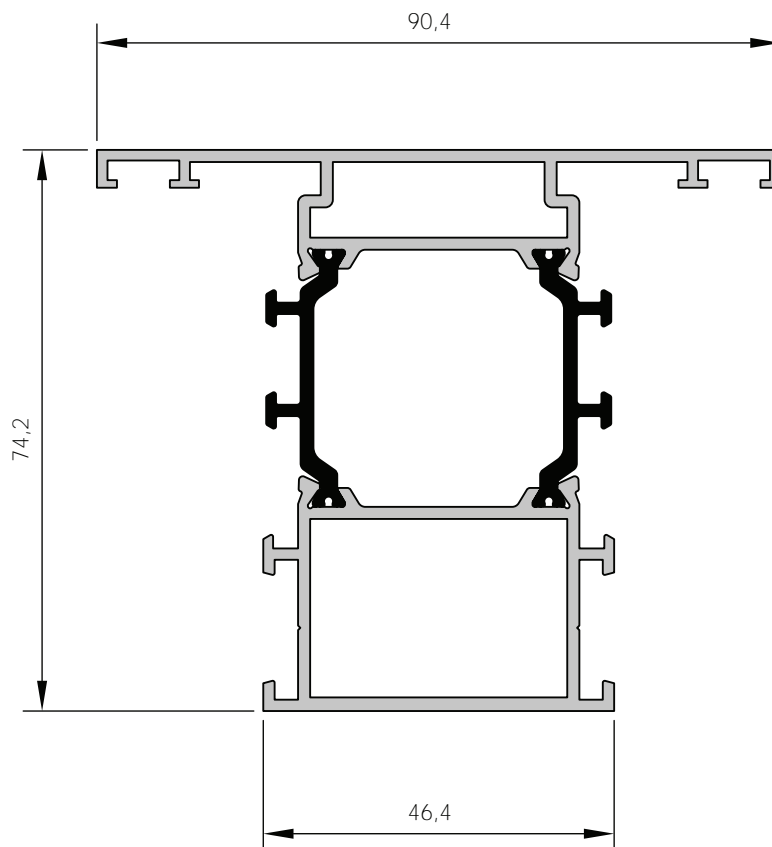

Escala 1:1



# A.175.080

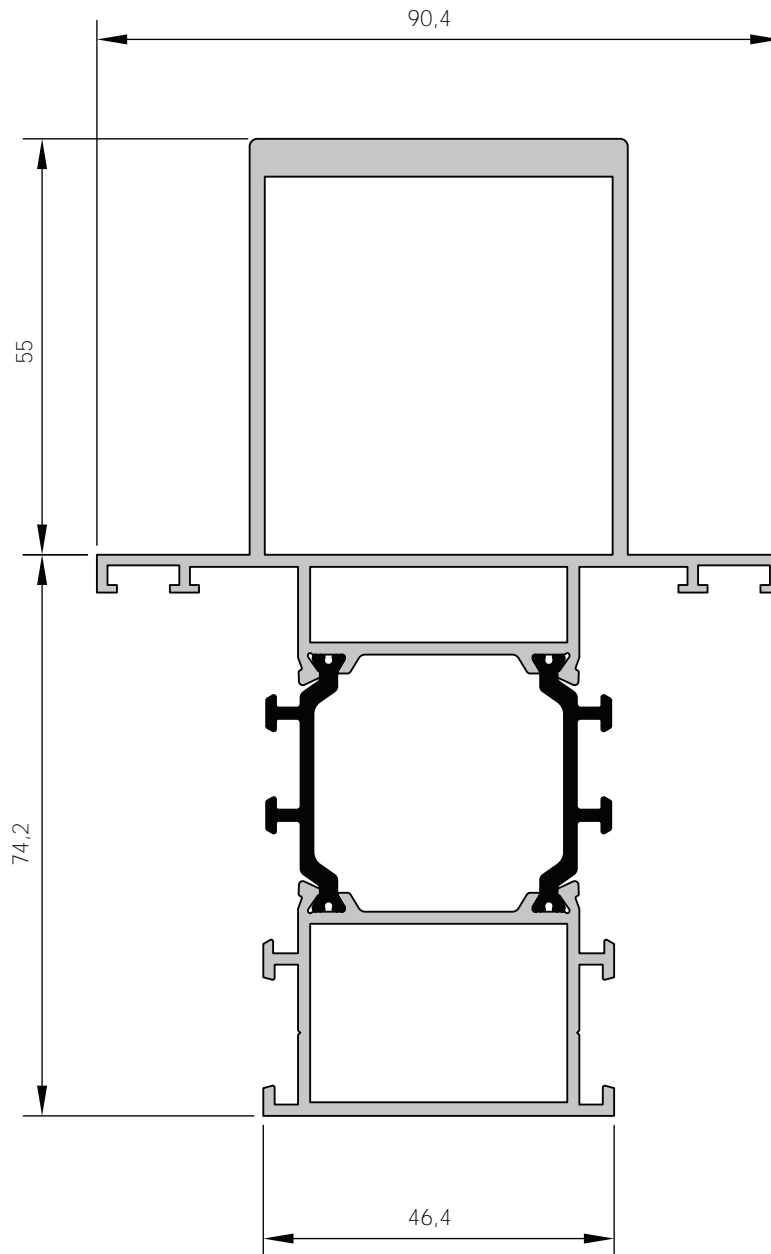

Escala 1:1

**A.175.260**

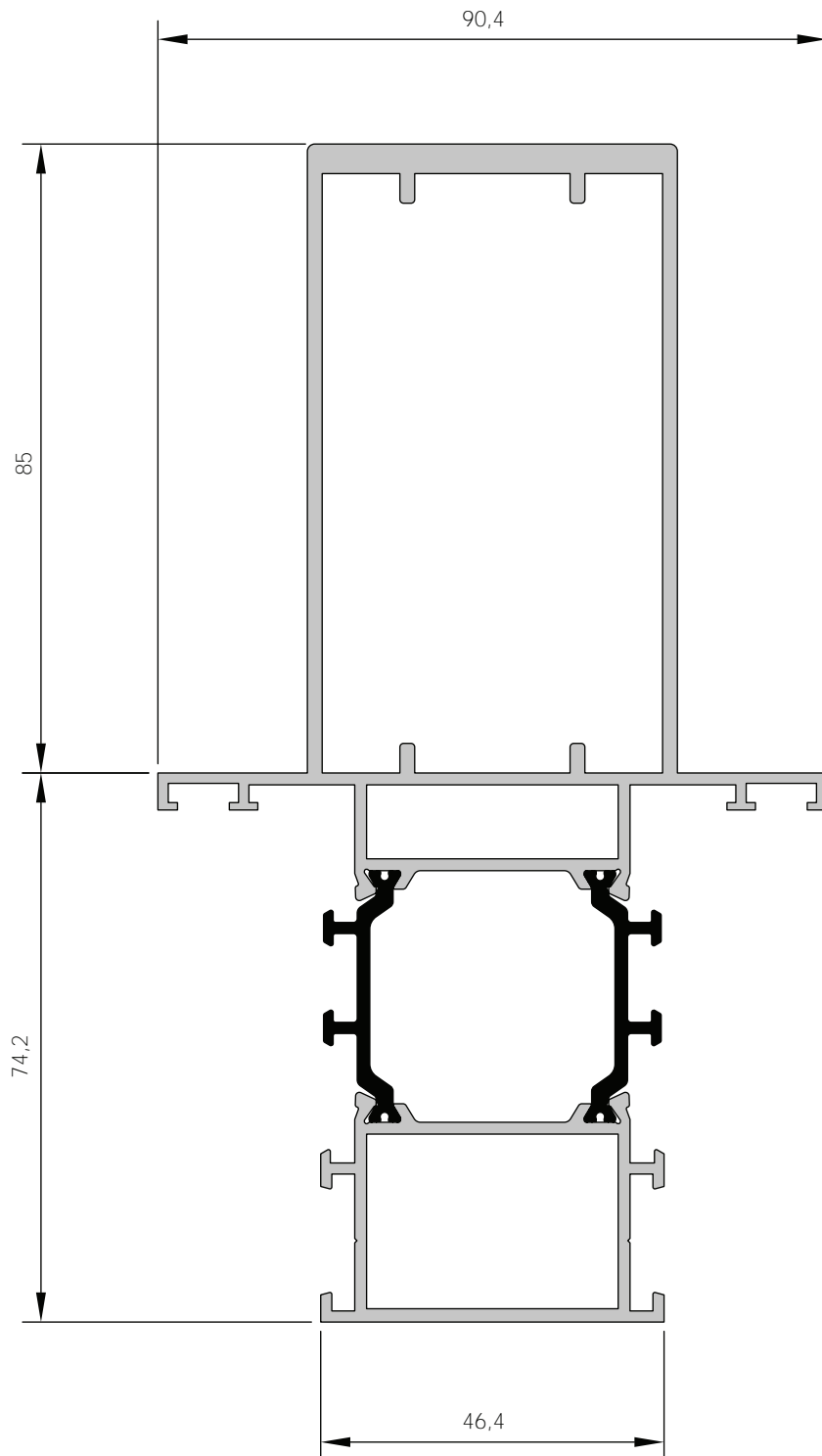

Escala 1:1

**A.175.130**

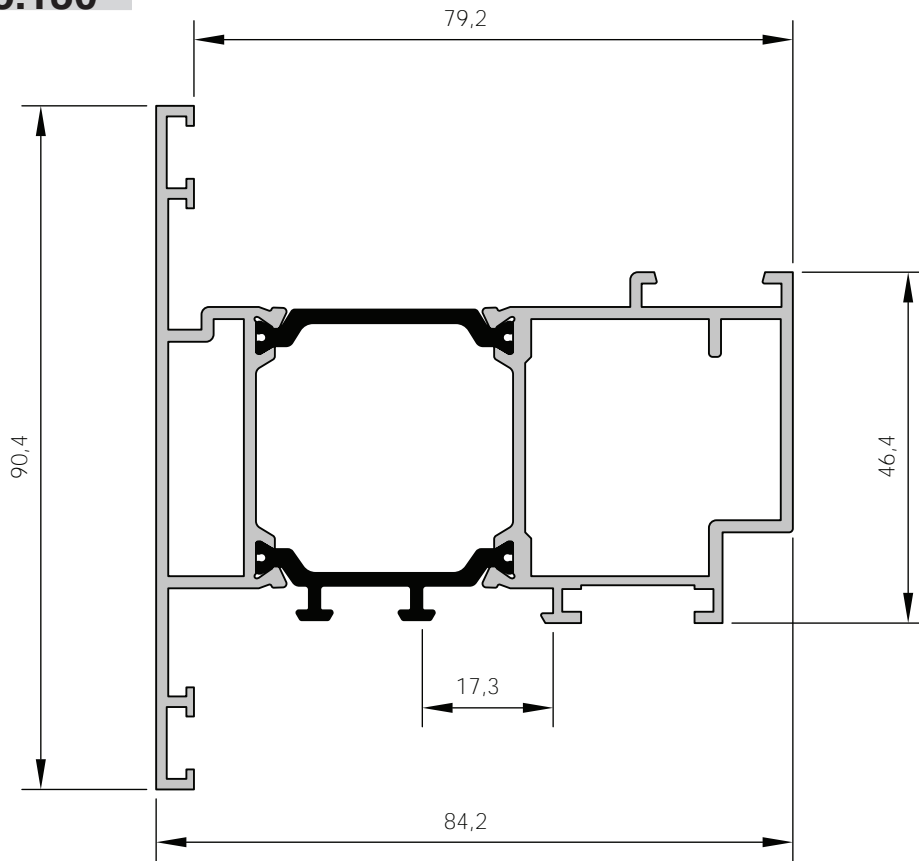

**A.175.140**

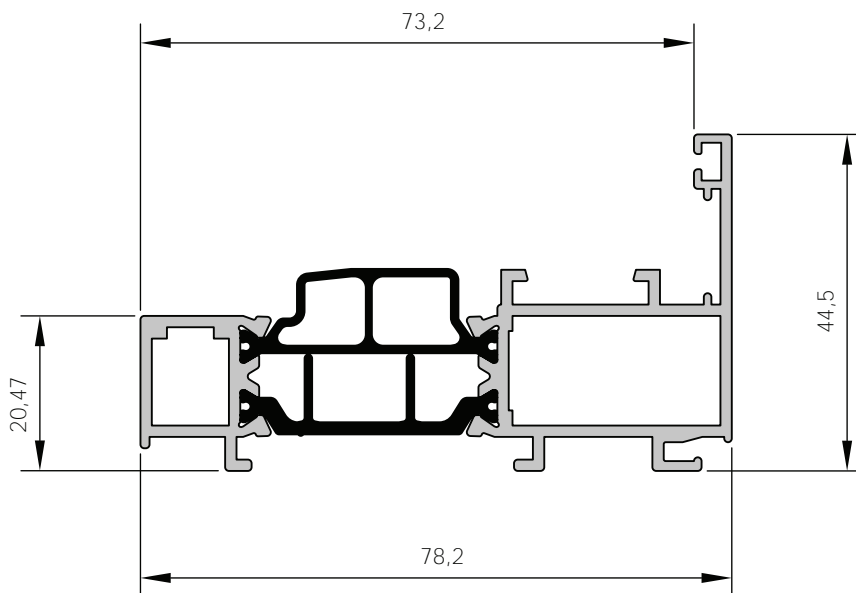

Escala 1:1

**A.175.170**

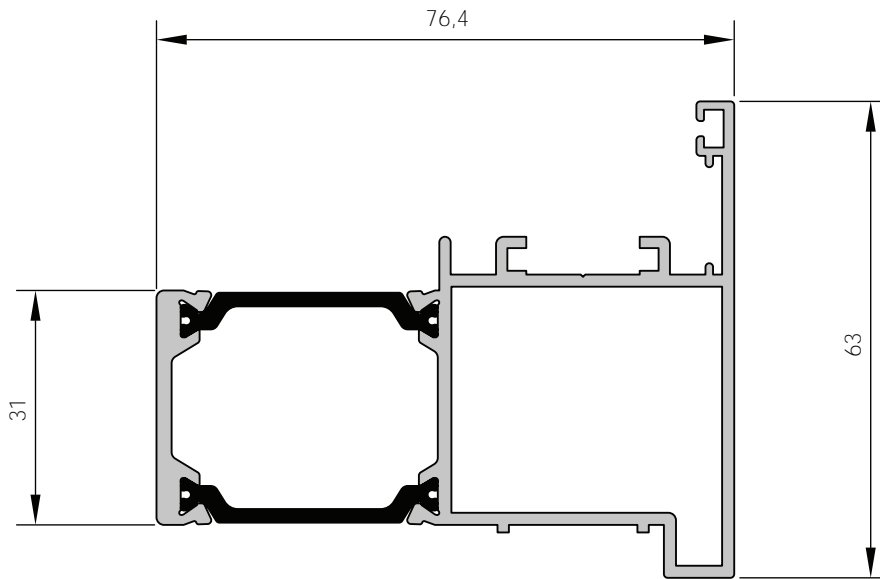

**A.175.910**

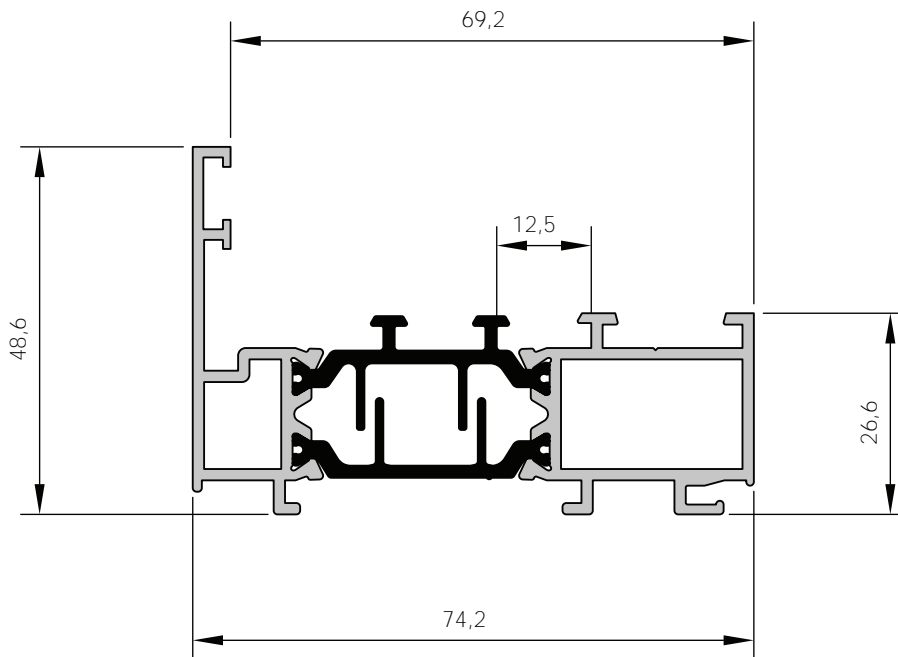

Escala 1:1

A.175.930

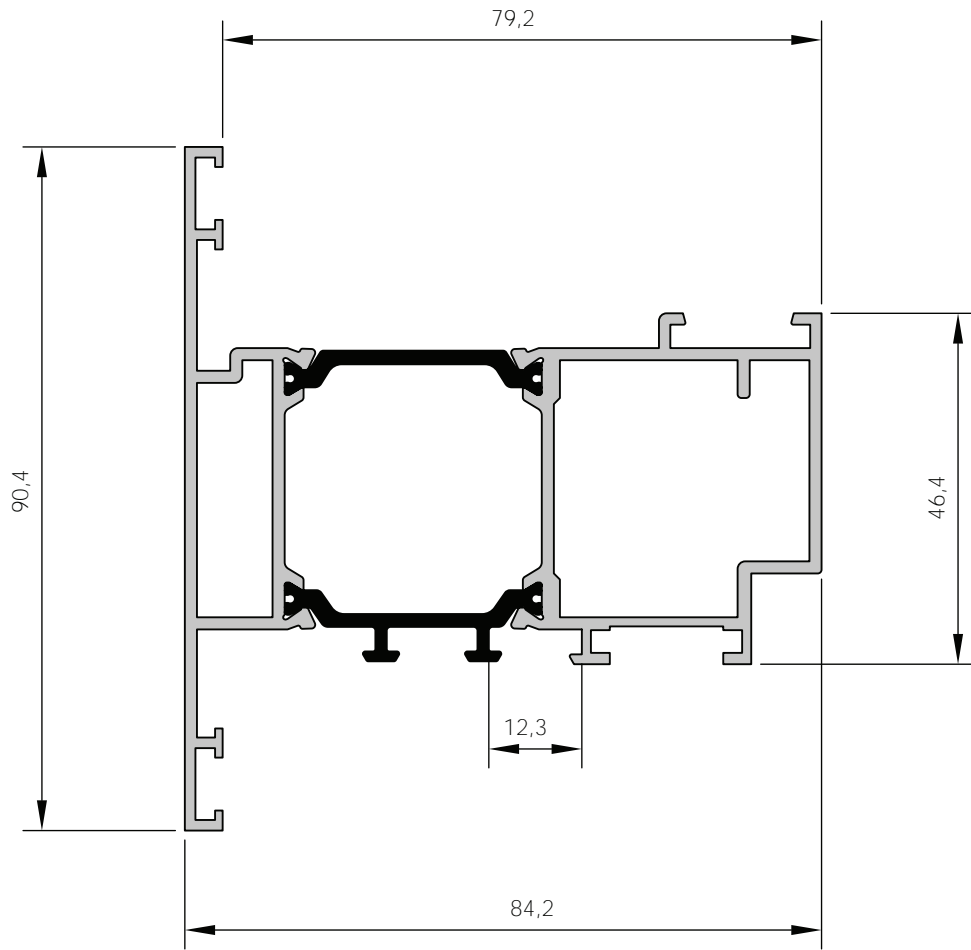

Escala 1:1

A.055.090

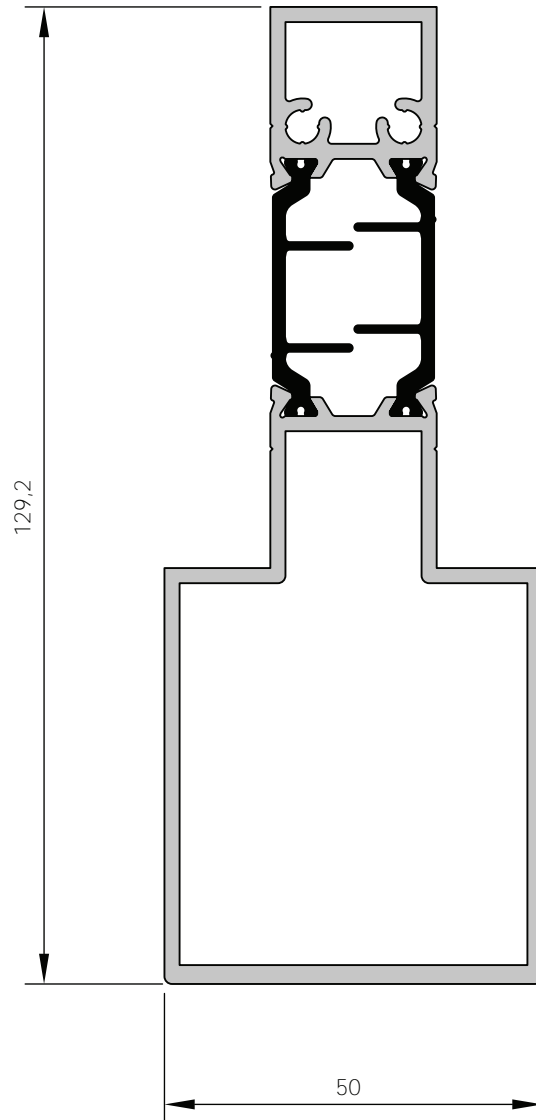

Escala 1:1

## A.055.110

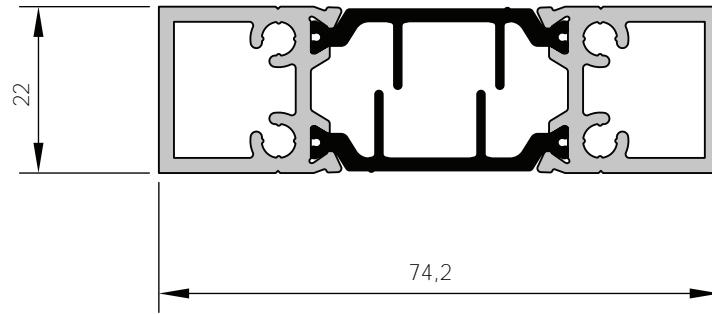

## A.080.029

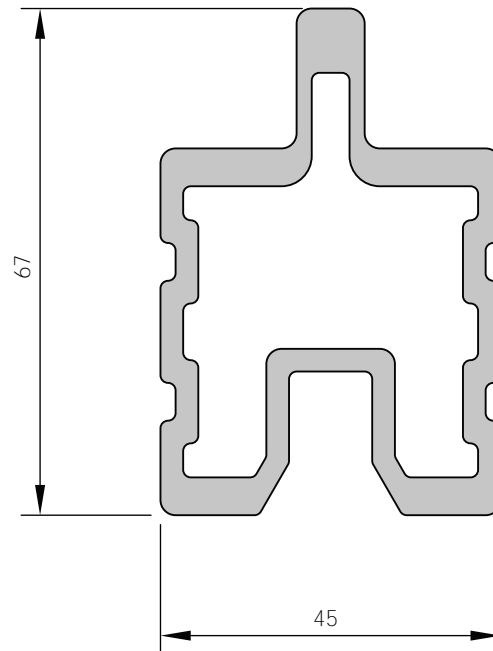

Escala 1:1

**B.055.580**

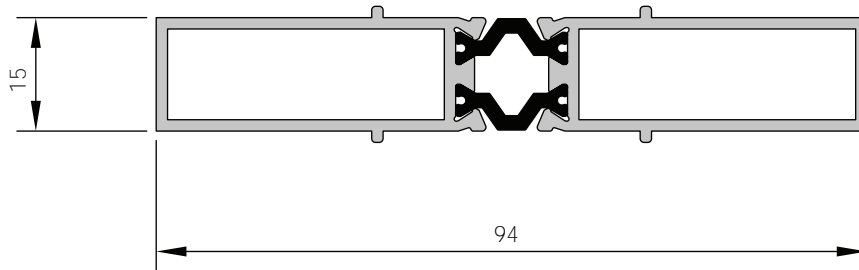

**B.095.080**

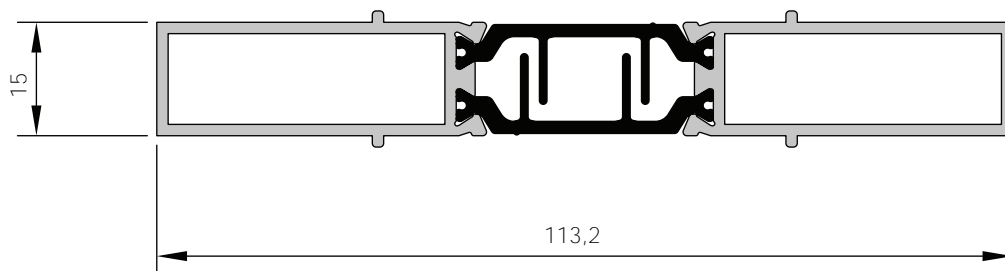

**B.150.030**

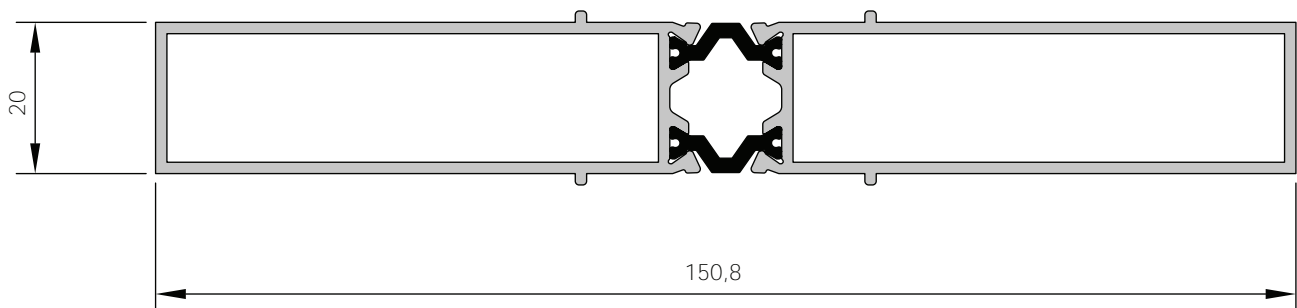

Escala 1:1



**F.009.135**

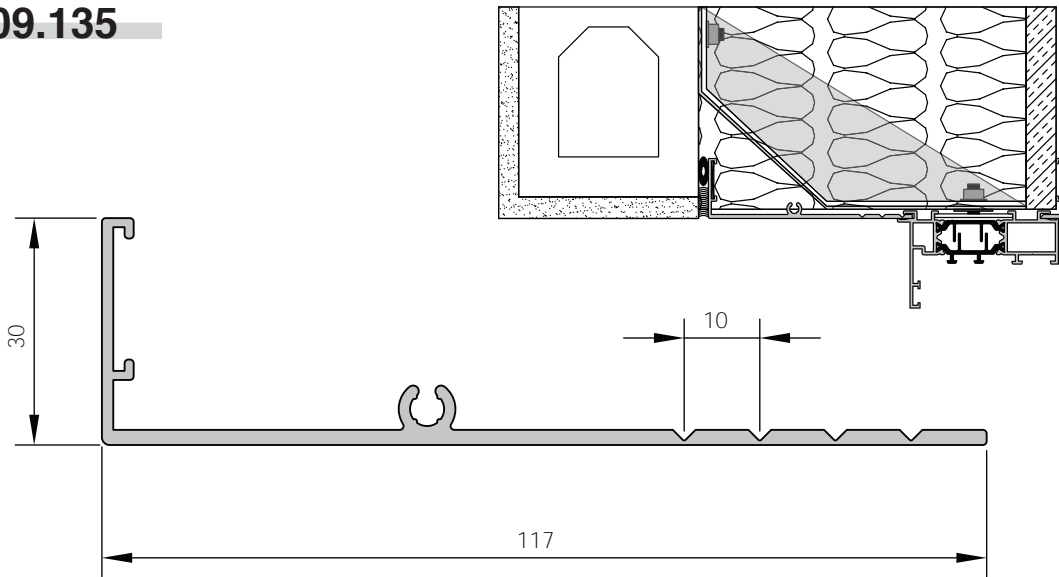

**F.009.137**

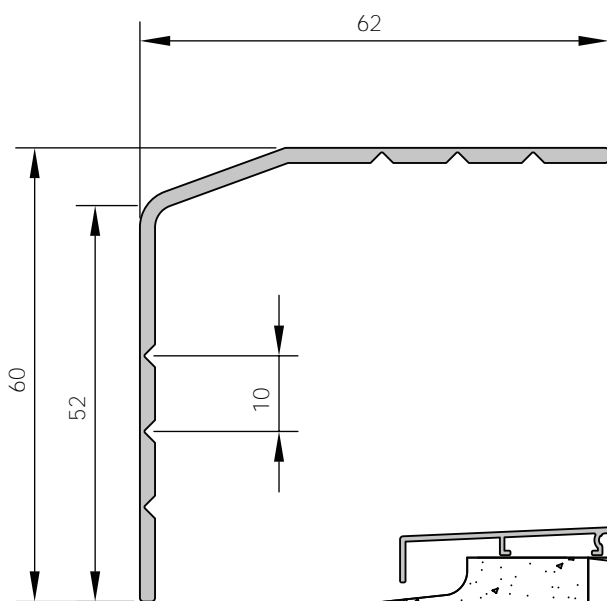

**F.009.138**

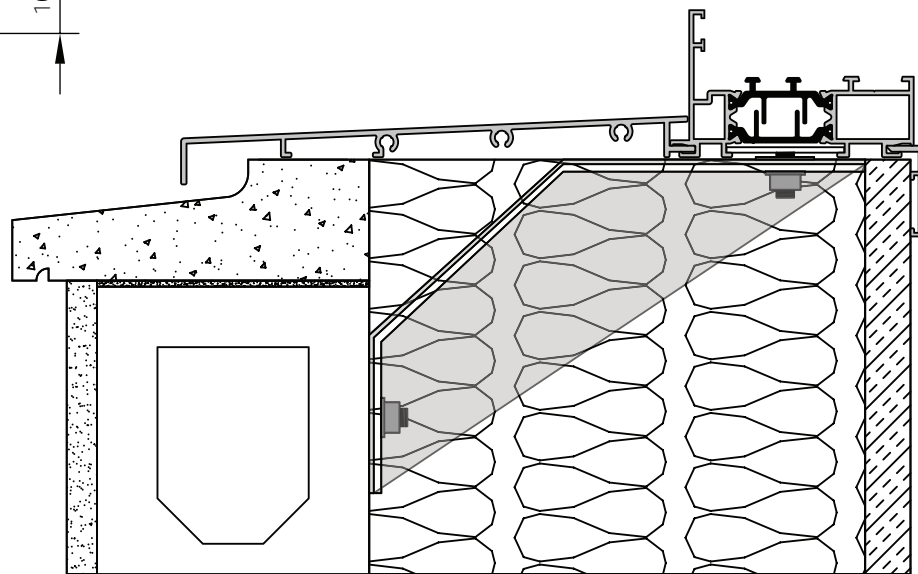
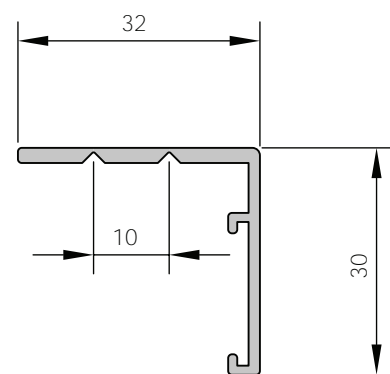

Escala 1:1

Produto  
6

Características Técnicas  
8

Perfis  
18

Seções  
46

Tipologias Construtivas  
68

Instruções Fabrico  
136

Instruções Montagem  
144

Acessórios  
152

F.009.136

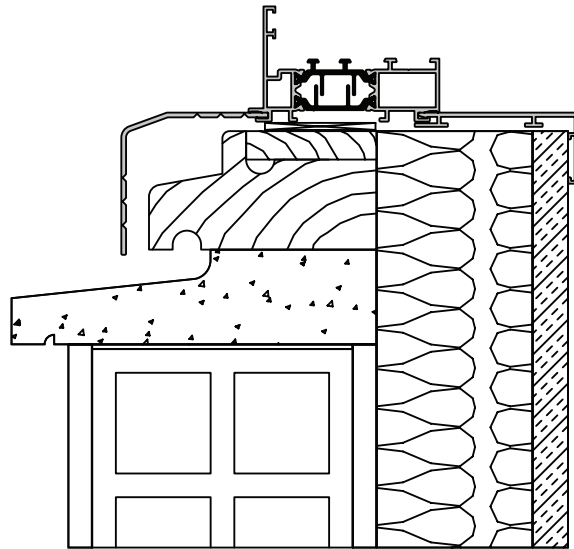
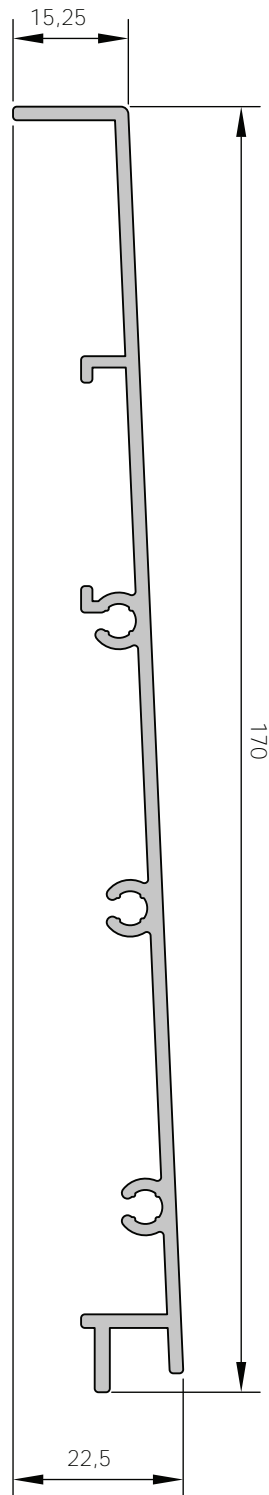

Escala 1:1

F.009.155

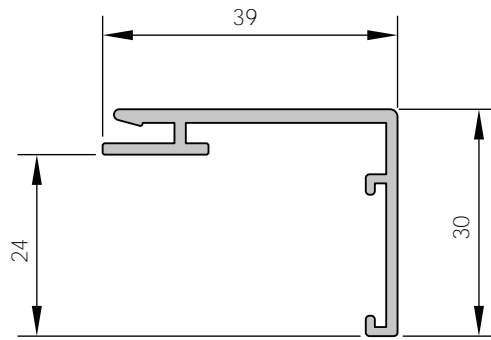

F.009.156

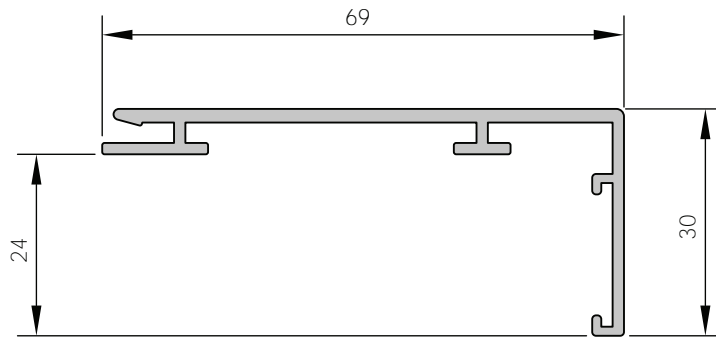

F.009.157

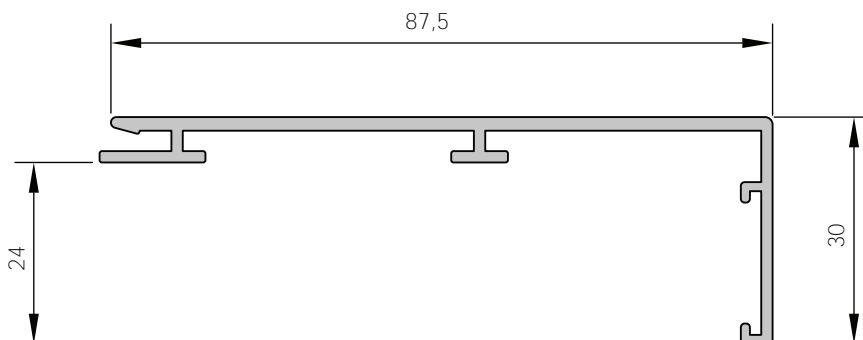

Escala 1:1

Produto  
6

Características Técnicas  
8

Perfis  
18

Seções  
46

Tipologias Construtivas  
68

Instruções Fabrico  
136

Instruções Montagem  
144

Acessórios  
152

**A.040.004**

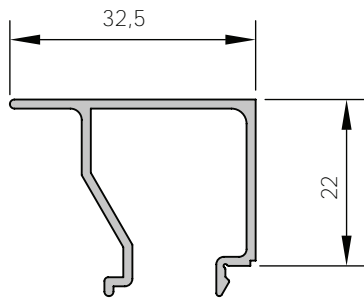

**A.040.025**

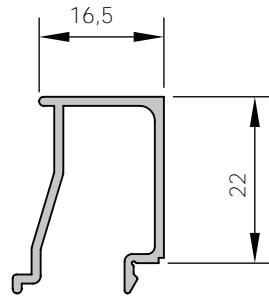

**A.040.026**

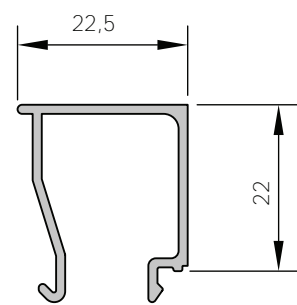

**A.040.039**

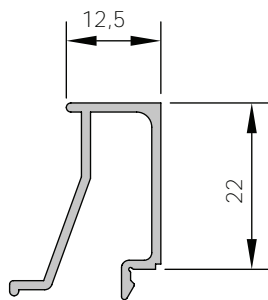

**A.040.050**

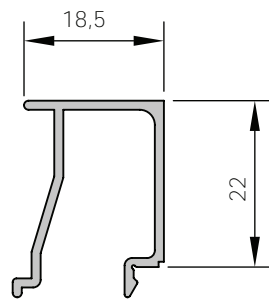

**A.040.069**

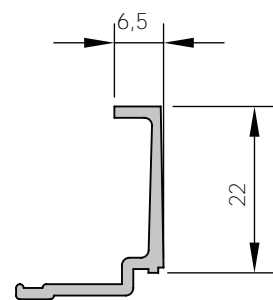

**A.040.070**

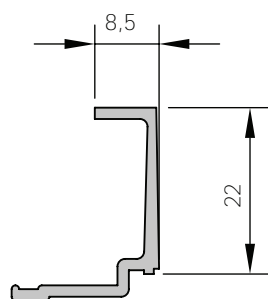

**A.040.107**

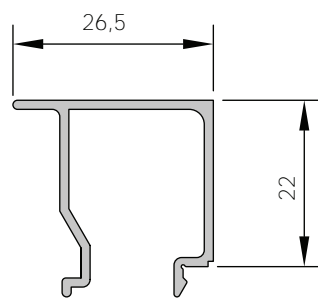

**A.040.110**

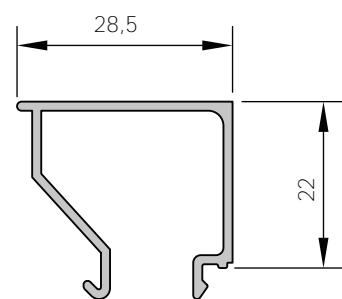

Escala 1:1

**A.040.133**

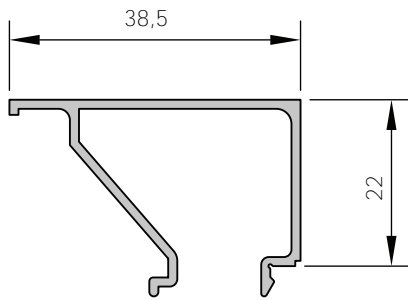

**A.040.140**

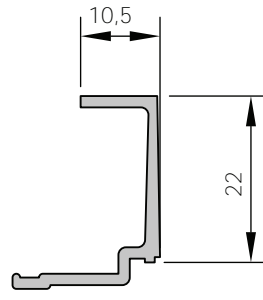

**A.040.141**

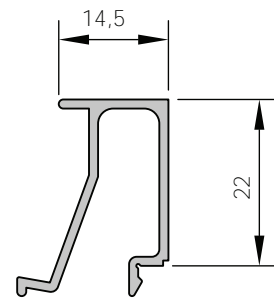

**A.040.142**

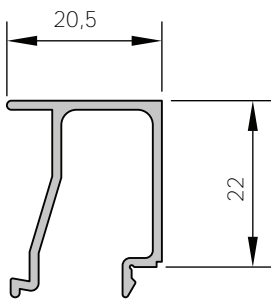

**A.040.143**

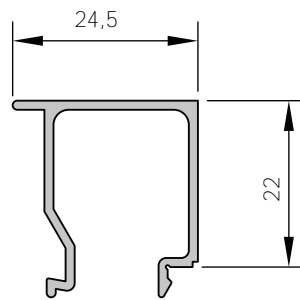

**A.040.144**

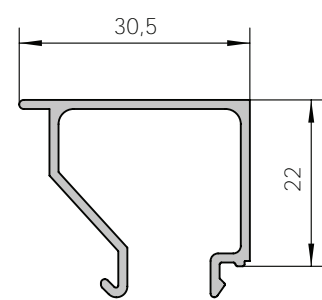

**A.040.146**

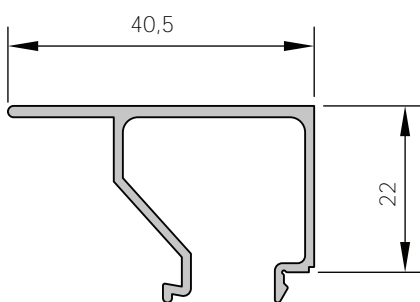

**A.040.147**

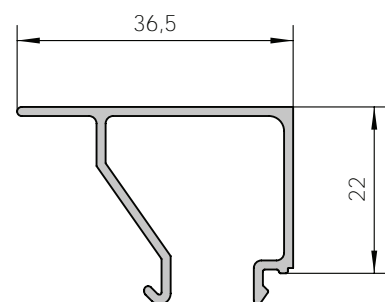

Escala 1:1

A.175.090

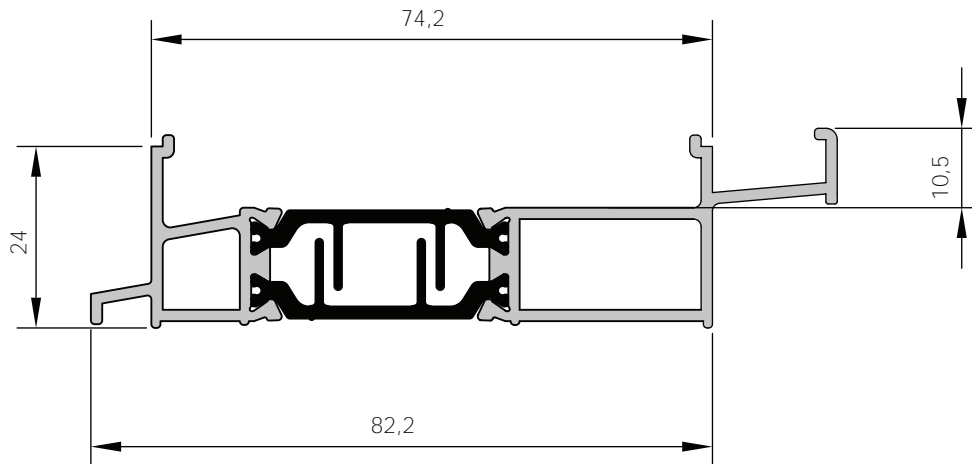

A.175.360

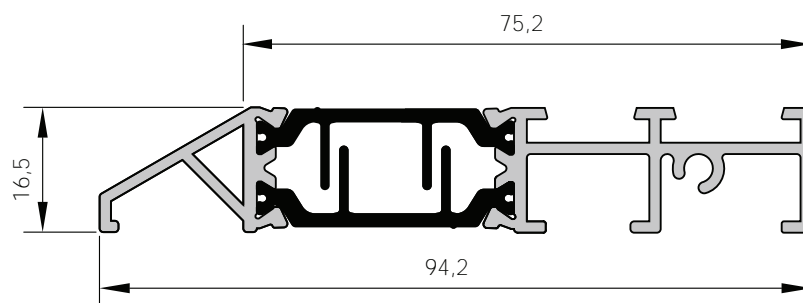

Escala 1:1

## A.175.210

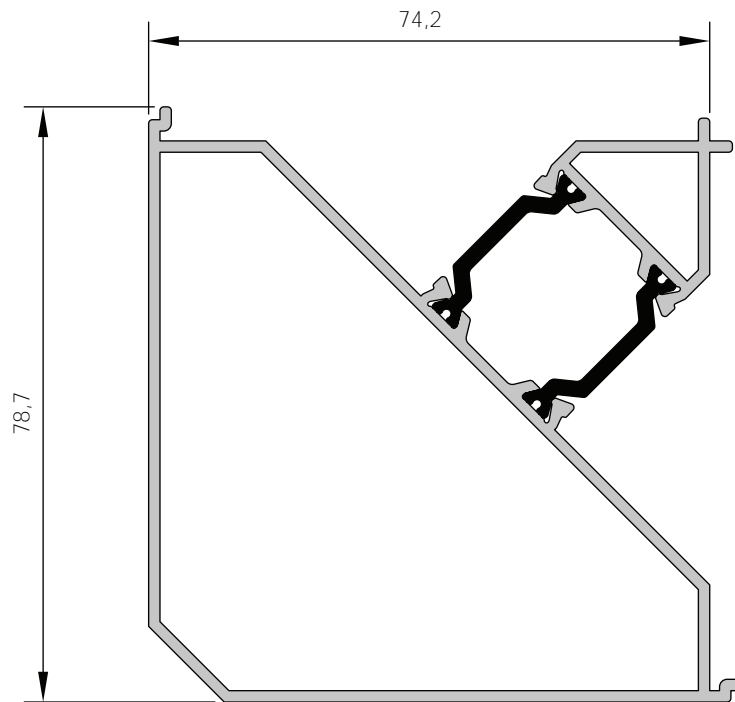

## A.175.330

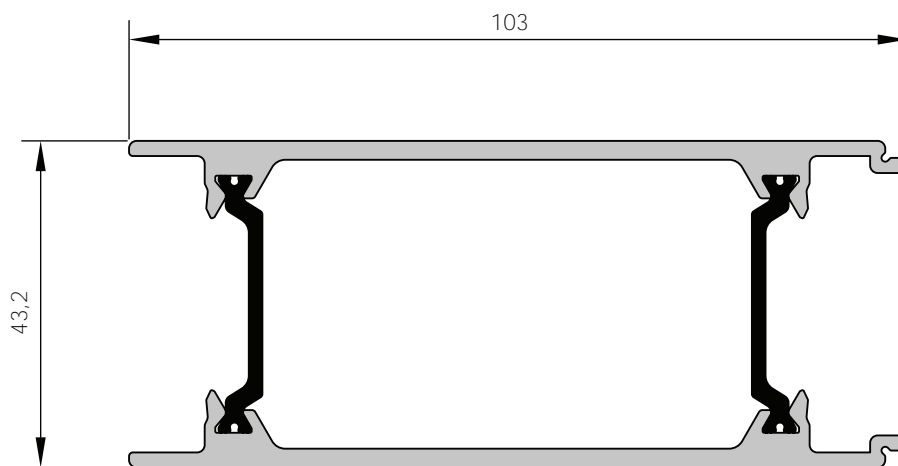

Escala 1:1

**A.100.013**

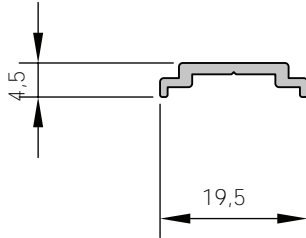

**A.100.023**

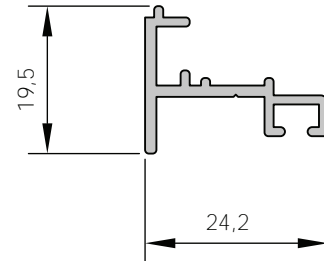

**A.040.048**

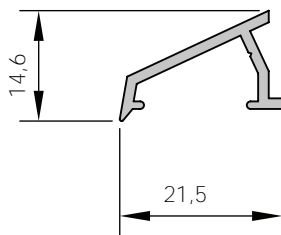

**A.055.015**

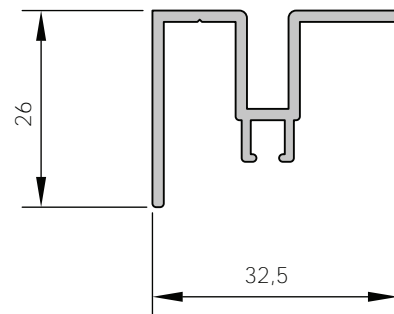

**F.009.139**

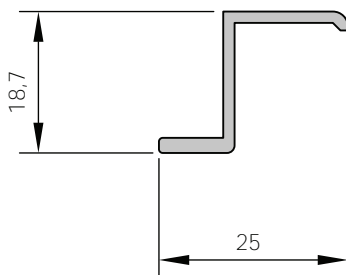

**F.010.140**

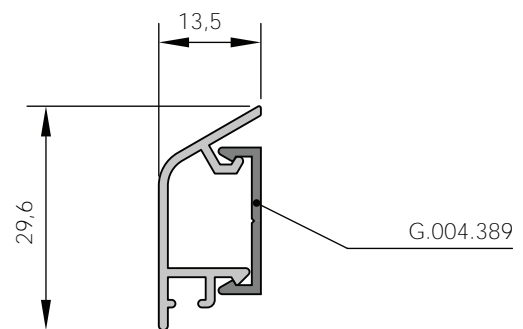

Escala 1:1





**Acessórios**  
152

**Instruções Montagem**  
144

**Instruções Fábrico**  
136

**Tipologias Construtivas**  
68

**Secções**  
46

**Perfis**  
18

**Características Técnicas**  
8

**Produto**  
6

# 04

## SECCÕES

medidas em mm

escala 1.1

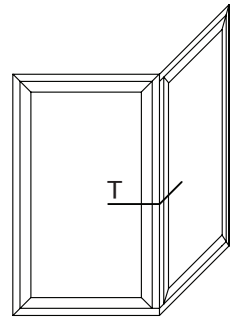
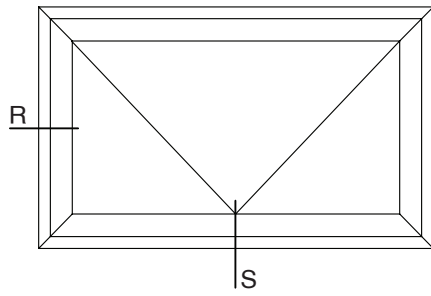
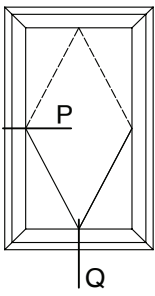
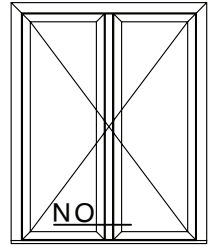
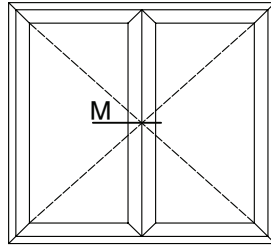
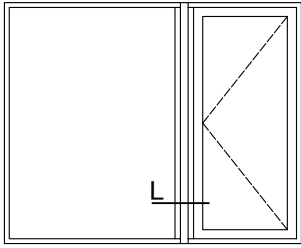
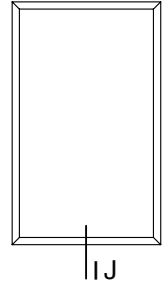
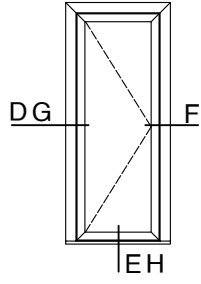
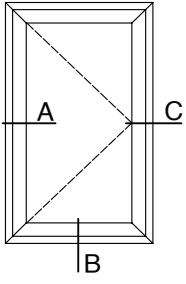

Extrusal

# SECÇÃO A JANELA ABRIR

A.175

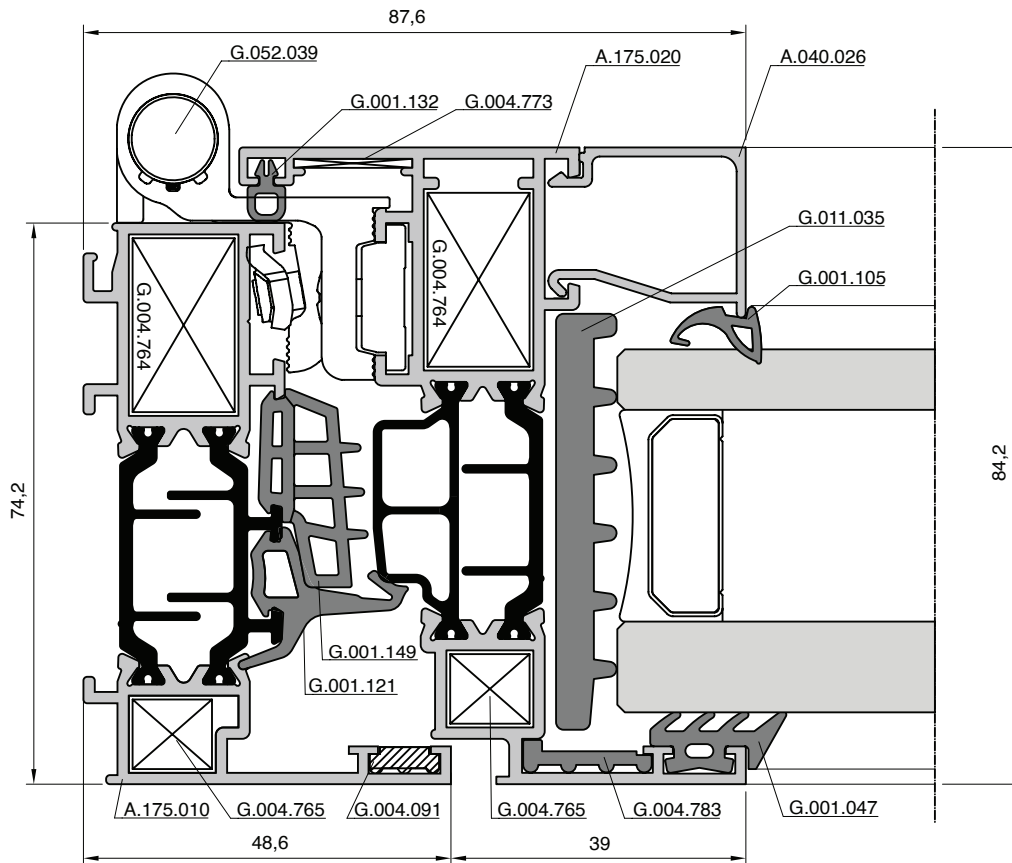
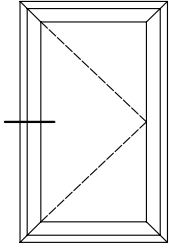

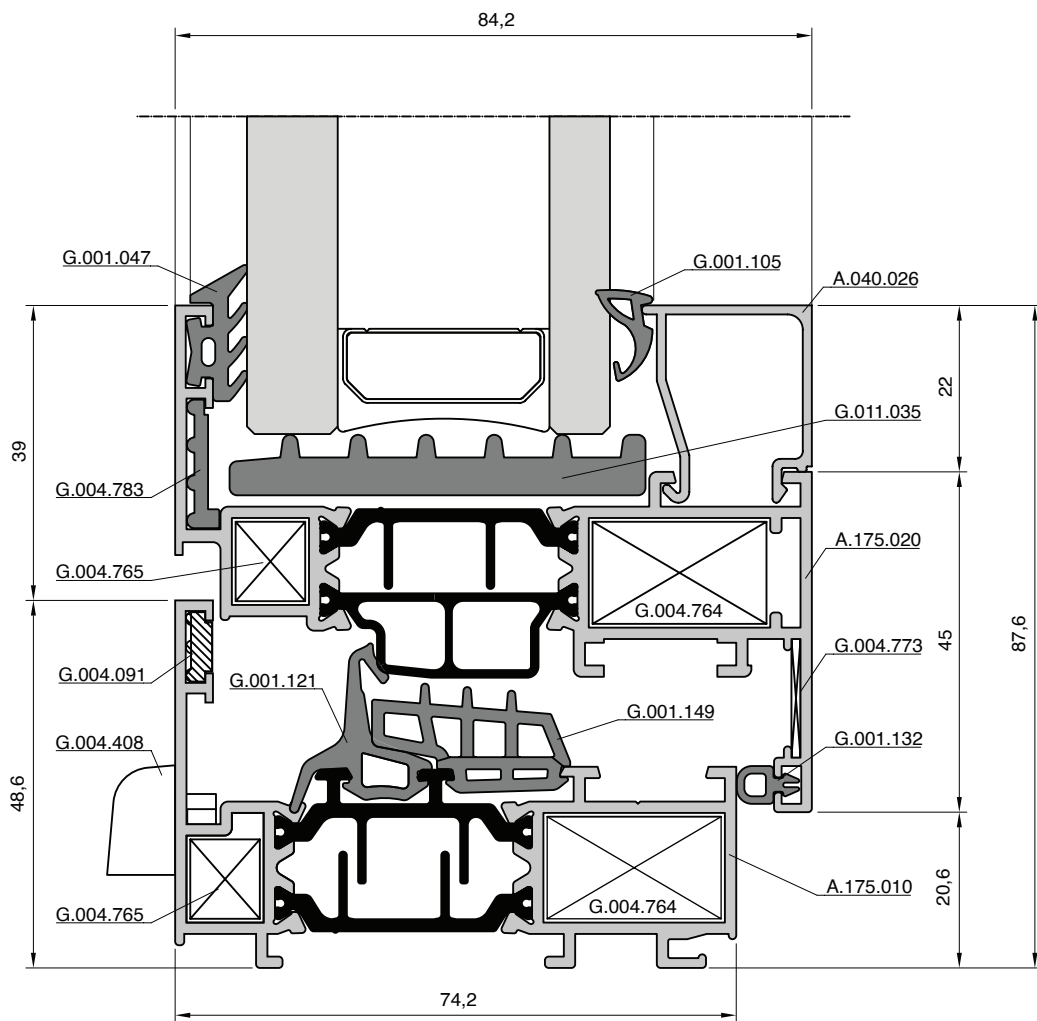
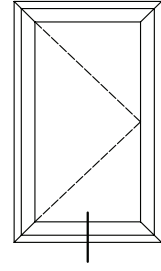

**SECÇÃO C**  
**JANELA ABRIR**

A.175

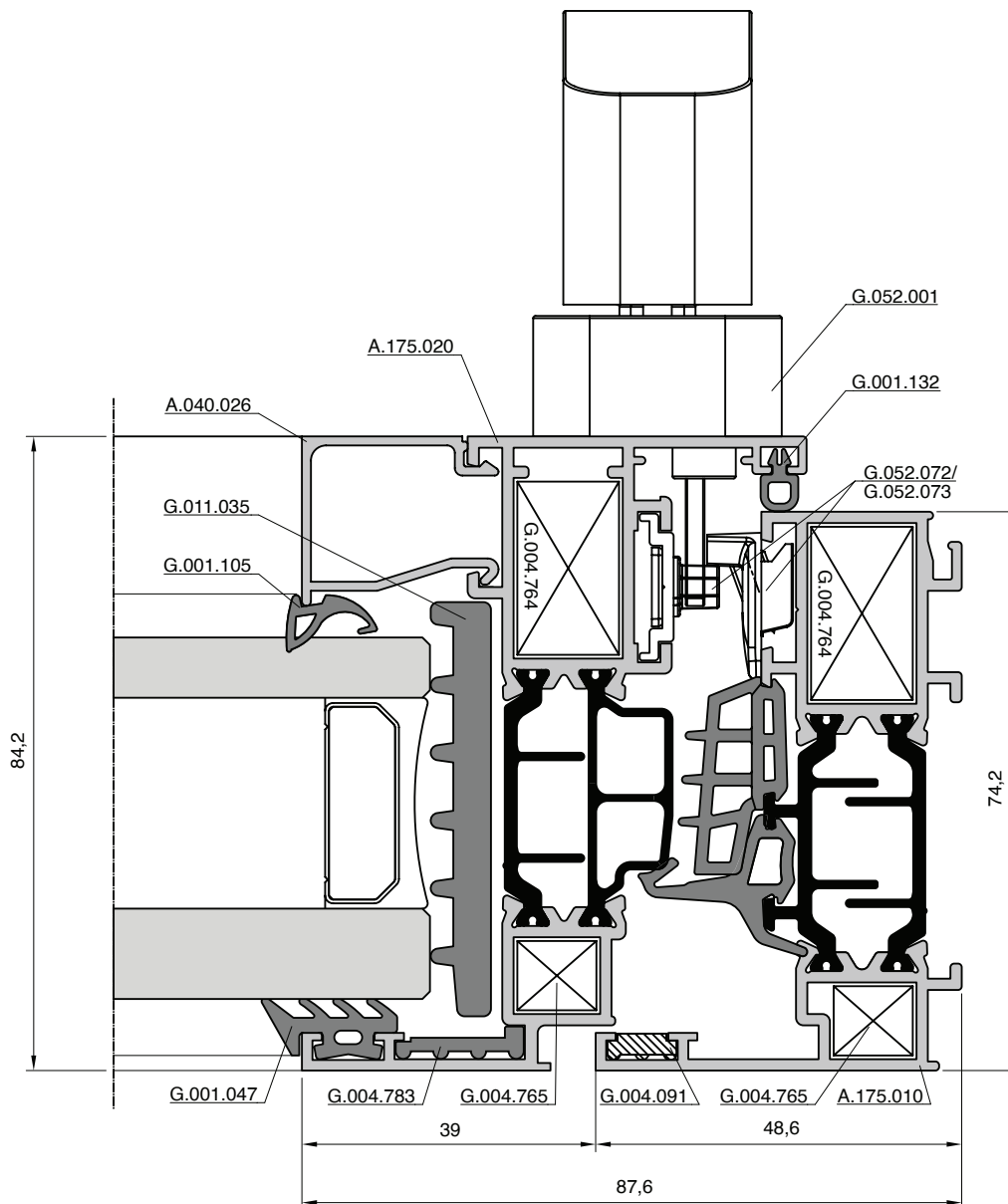
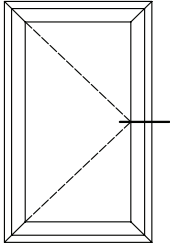

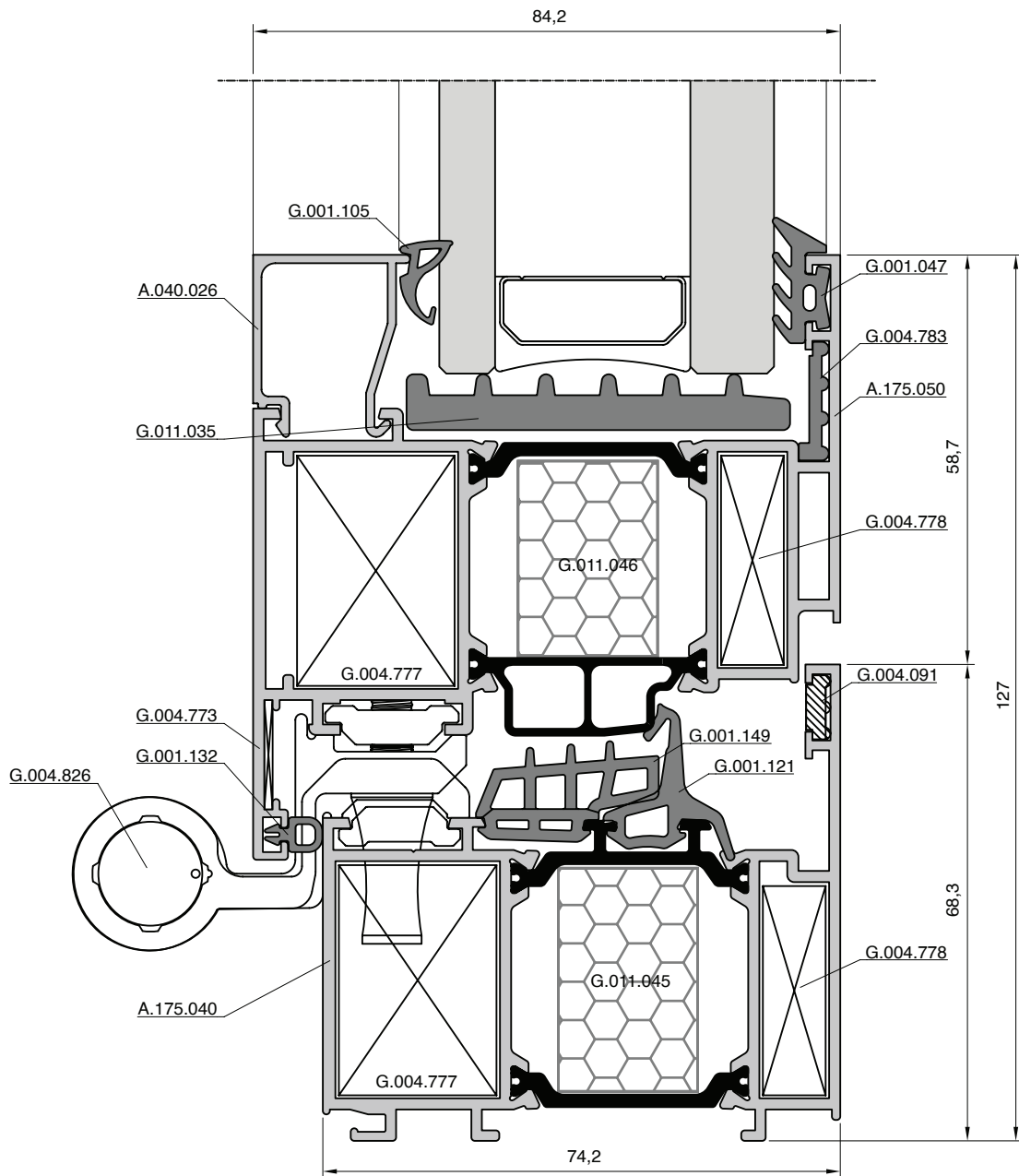
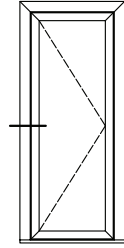

# SECCÃO E PORTA

A.175

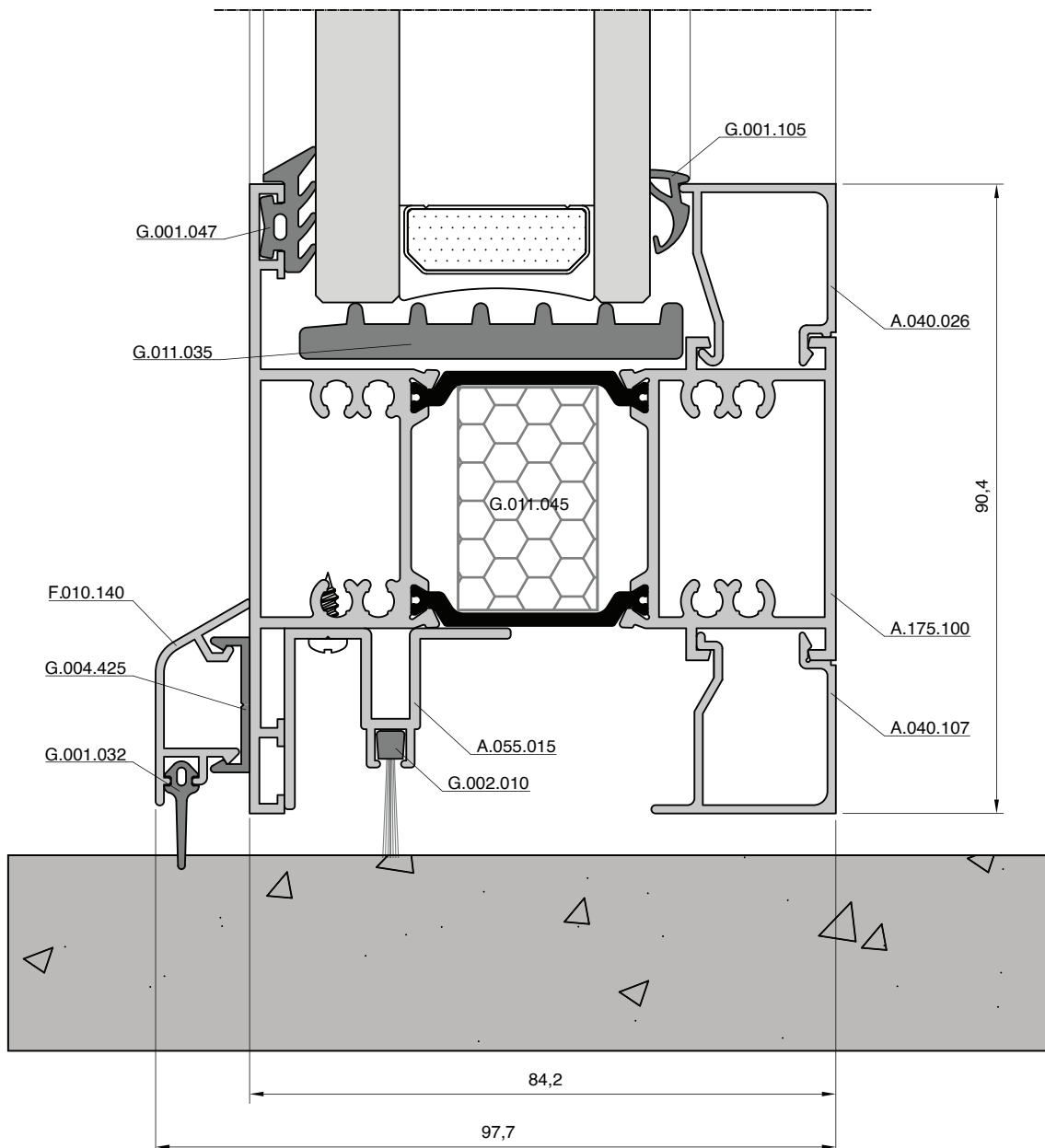
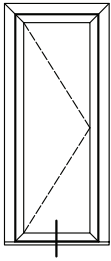



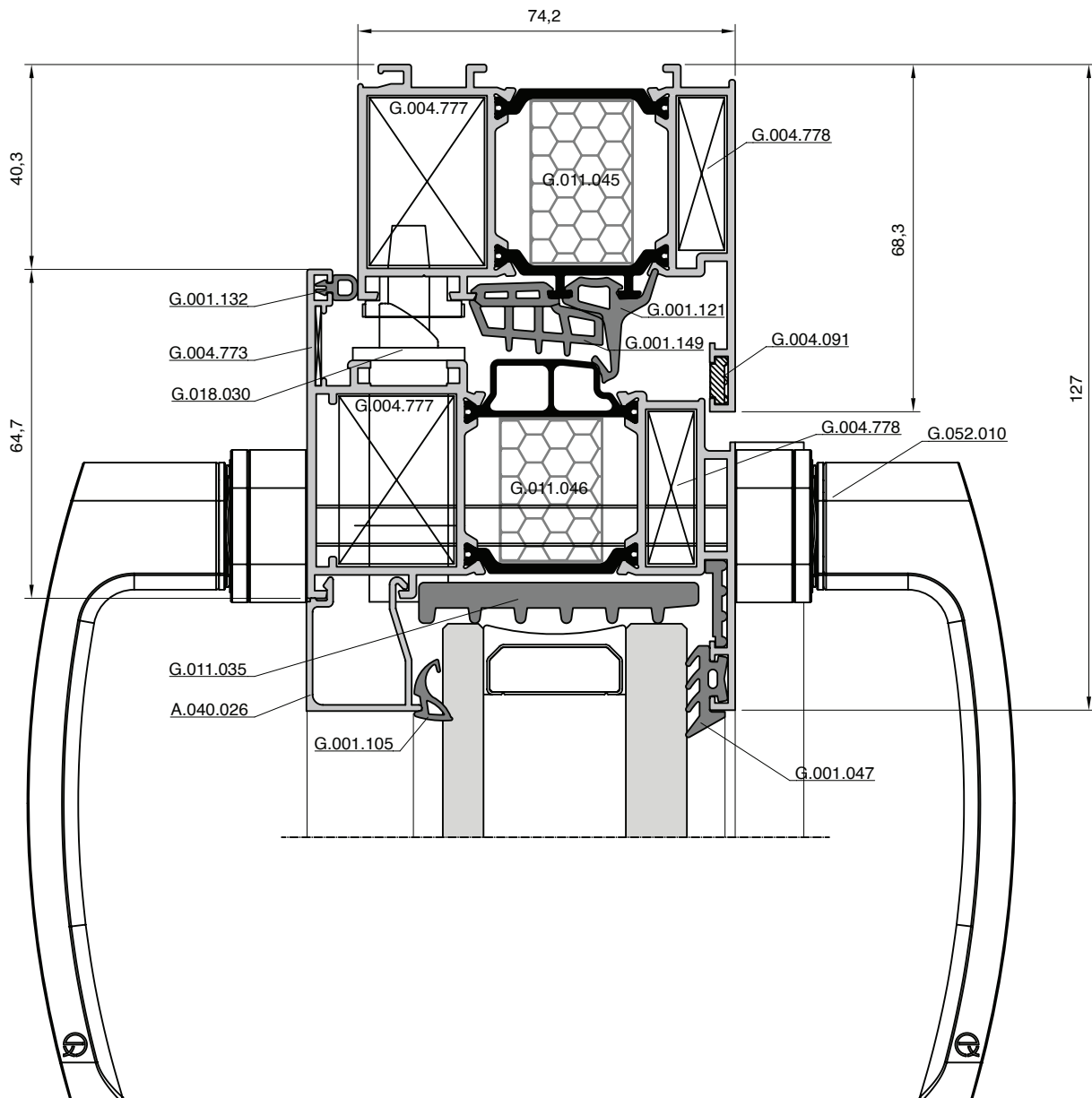
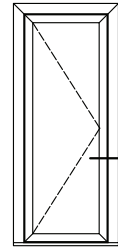

Produto  
6

Características Técnicas  
8

Perfis  
18

Seções  
46

Tipologias Construtivas  
68

Instruções Fabrico  
136

Instruções Montagem  
144

Acessórios  
152

**SECÇÃO G**  
**PORTA - ABERTURA EXTERIOR**

A.175

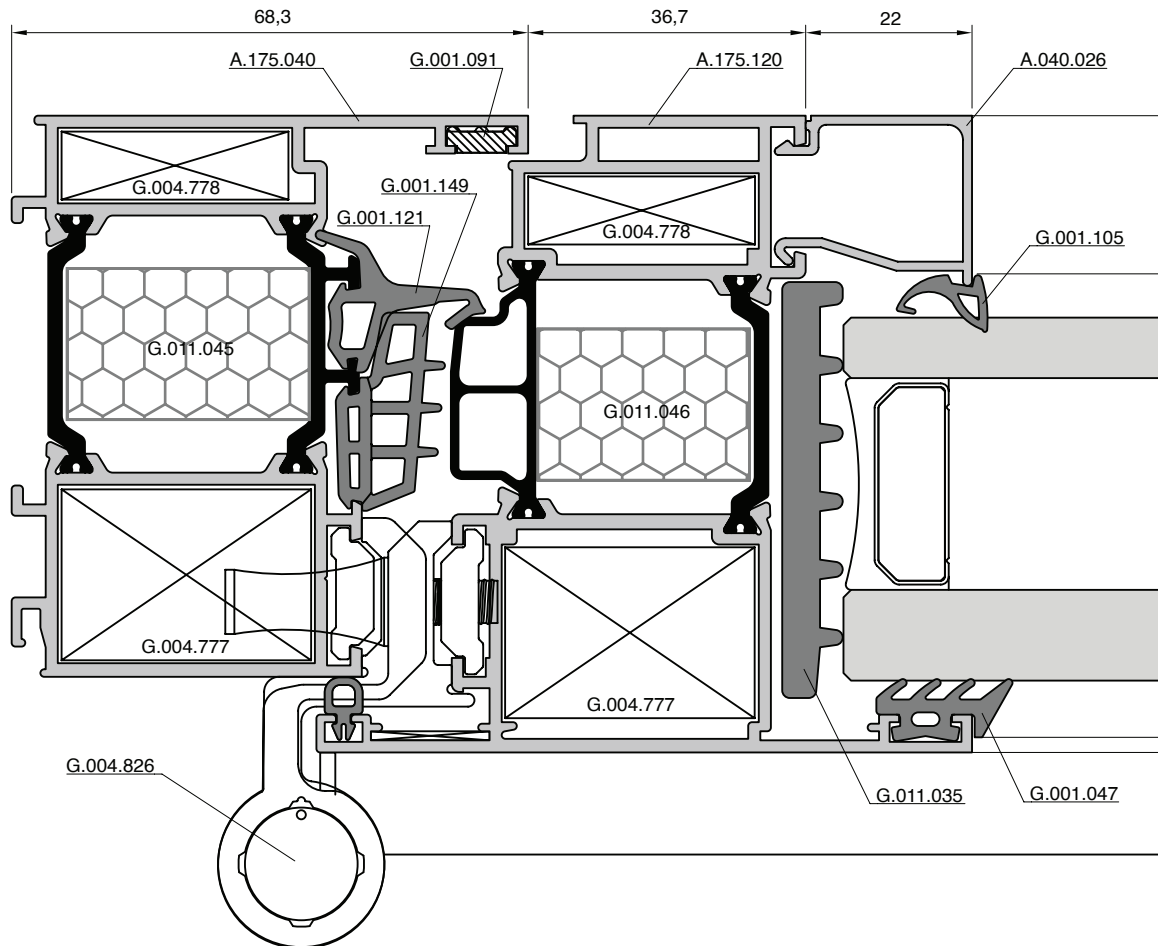
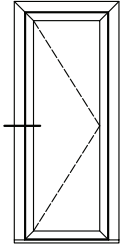

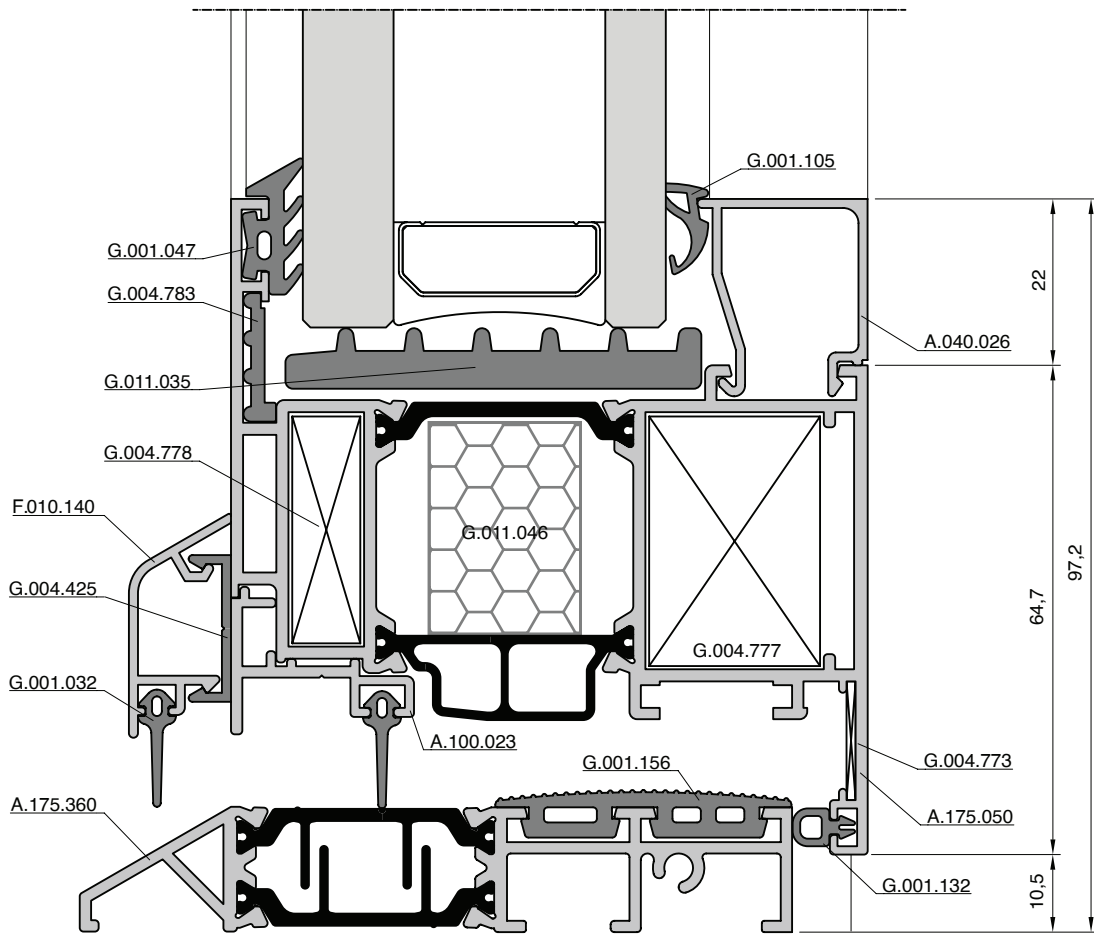
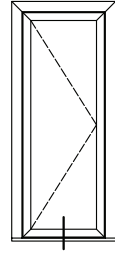

Produto  
6

Características Técnicas  
8

Perfis  
18

Seções  
46

Tipologias Construtivas  
68

Instruções Fabrico  
136

Instruções Montagem  
144

Acessórios  
152

**SECÇÃO I  
FIXO**

A.175

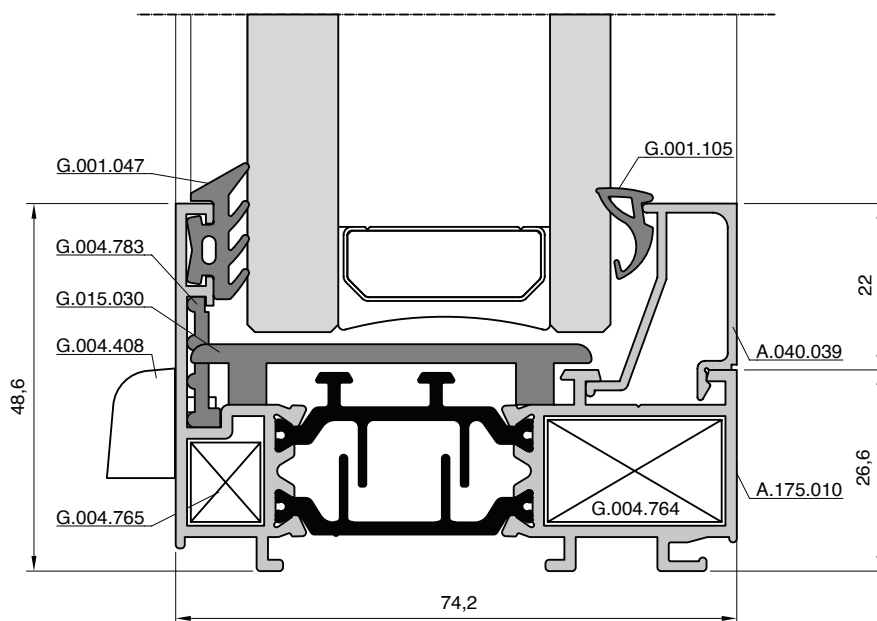
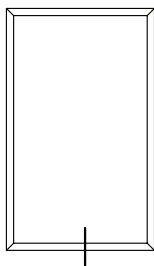

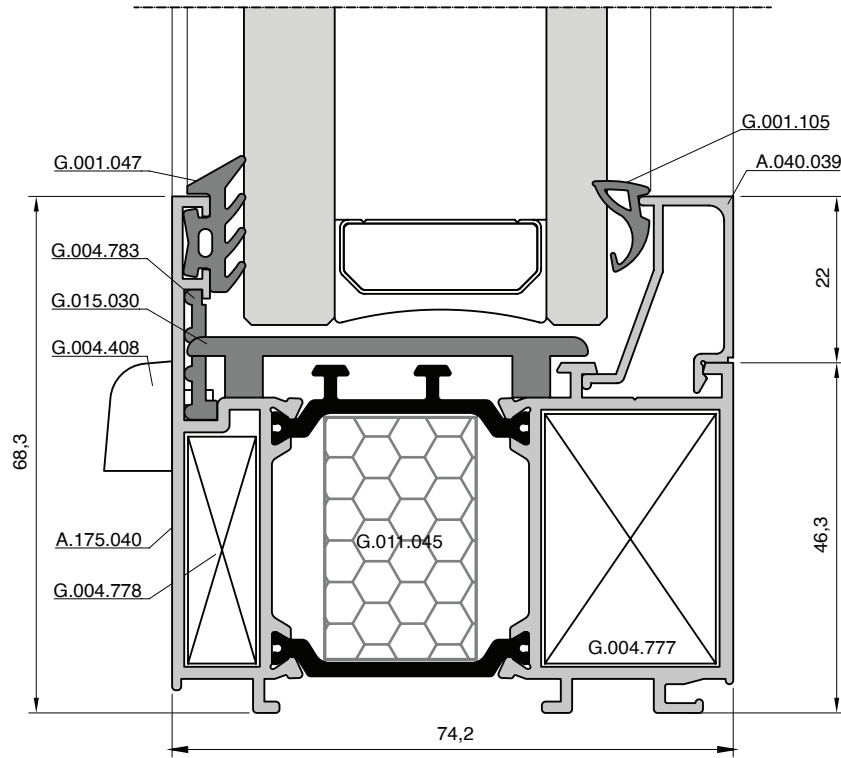
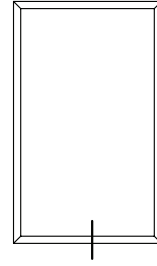

Produto  
6

Características Técnicas  
8

Perfis  
18

Seções  
46

Tipologias Construtivas  
68

Instruções Fabrico  
136

Instruções Montagem  
144

Acessórios  
152

**SECCÃO L**  
**SACADA C/ ENVIDRAÇADO FIXO**  
 A.175 (r1)

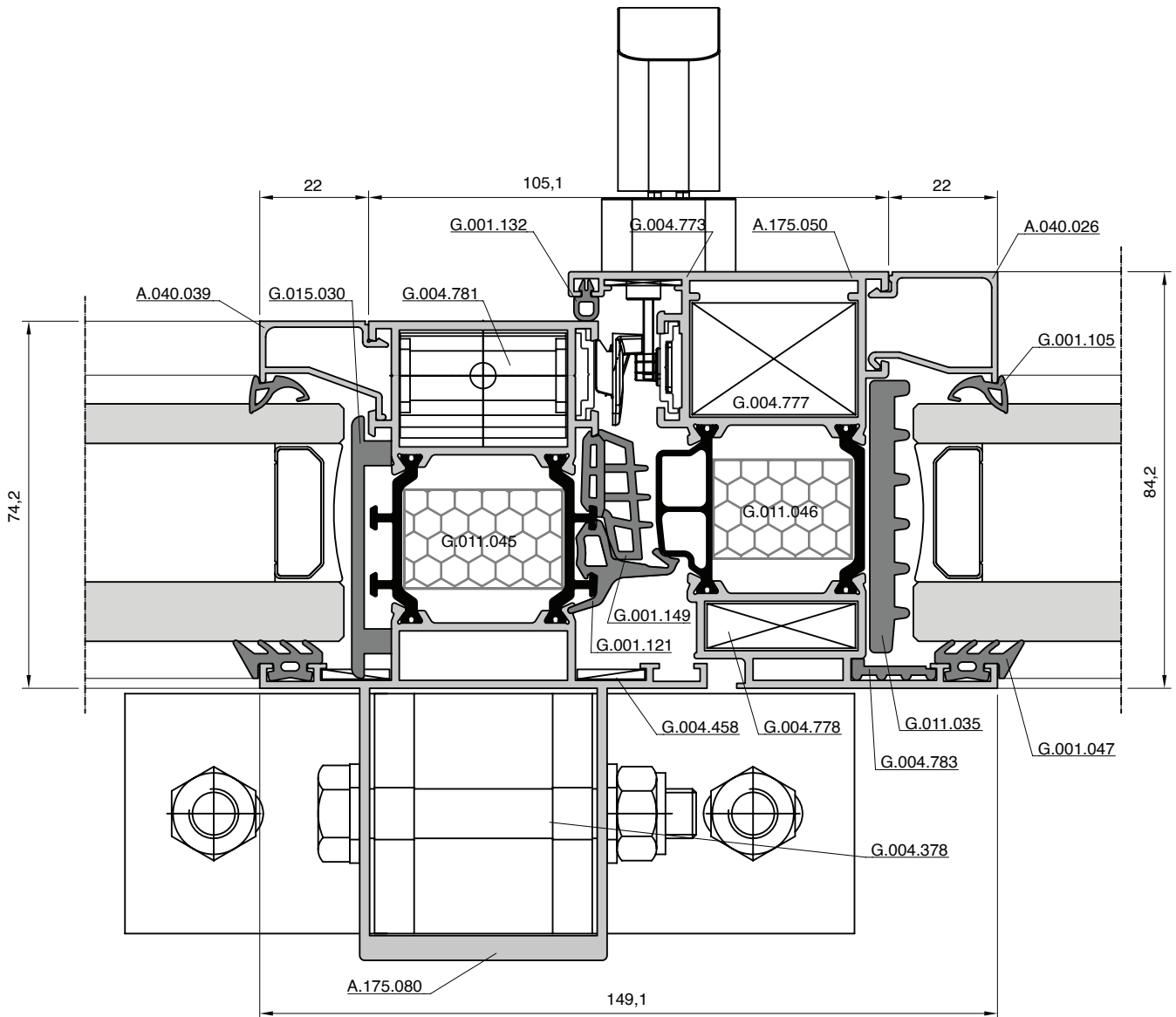
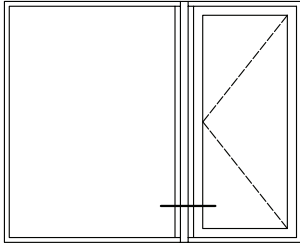

# SECCÃO M JANELA DUAS FÓLHAS

A.175

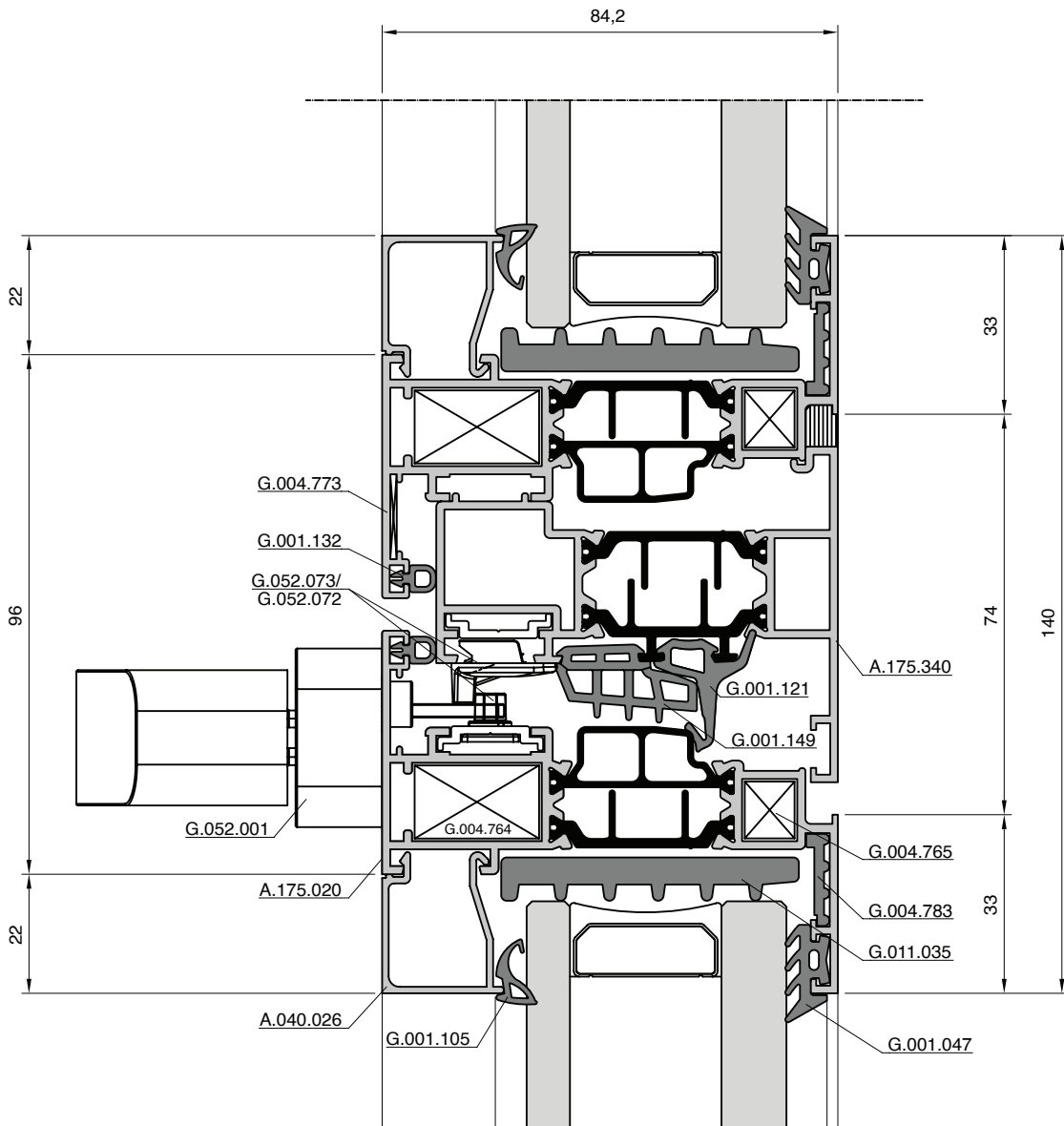
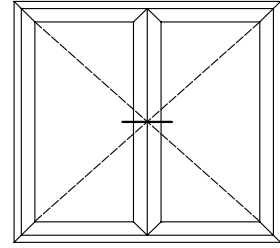

Produto  
6

Características Técnicas  
8

Perfis  
18

Seções  
46

Tipologias Construtivas  
68

Instruções Fabrico  
136

Instruções Montagem  
144

Acessórios  
152

**SECÇÃO N**  
**PORTA DUAS FOLHAS**  
A.175

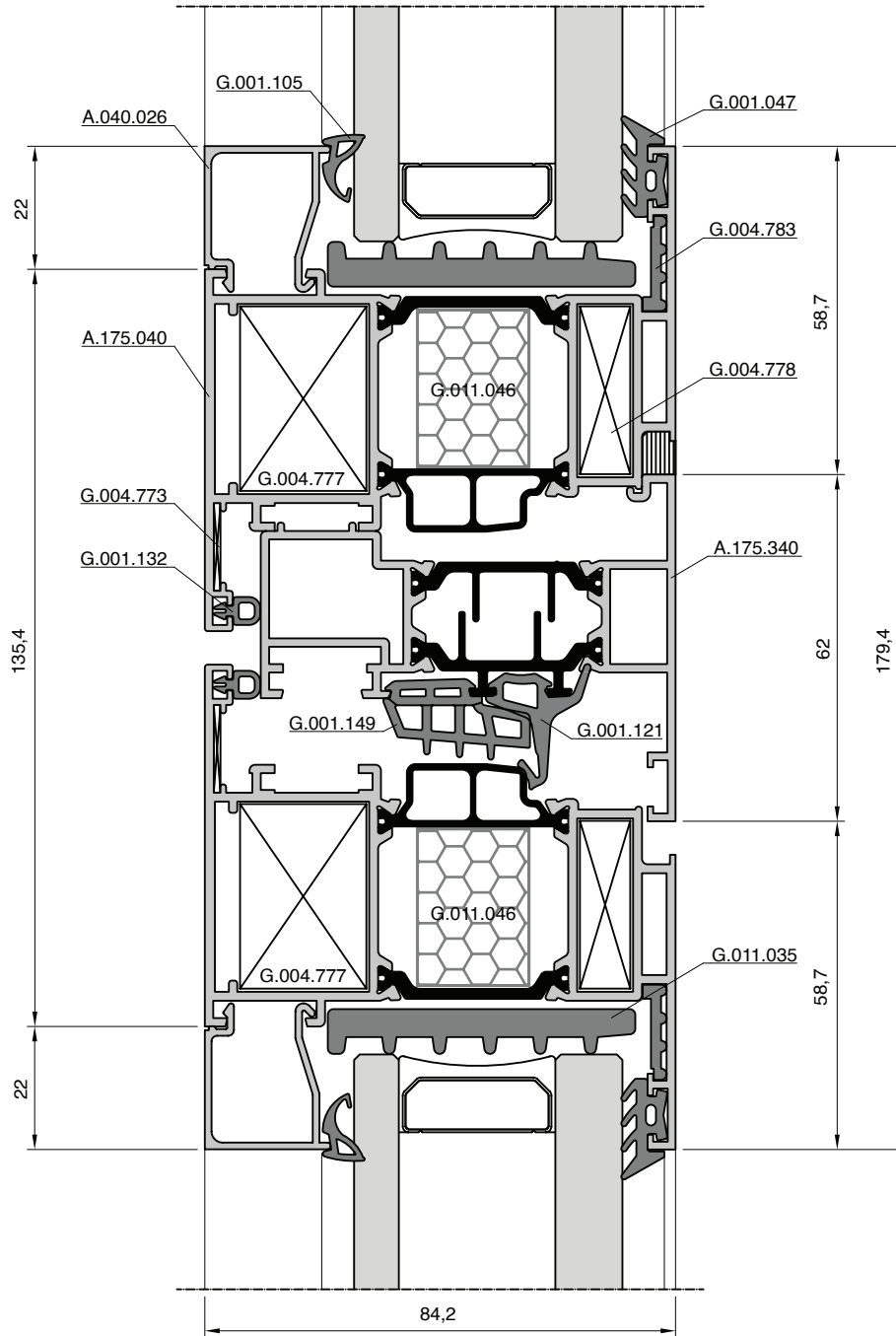
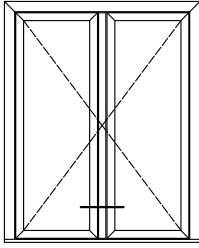



# SECCÃO O

## PORTA DUAS FOLHAS - ABERTURA EXTERIOR

A.175

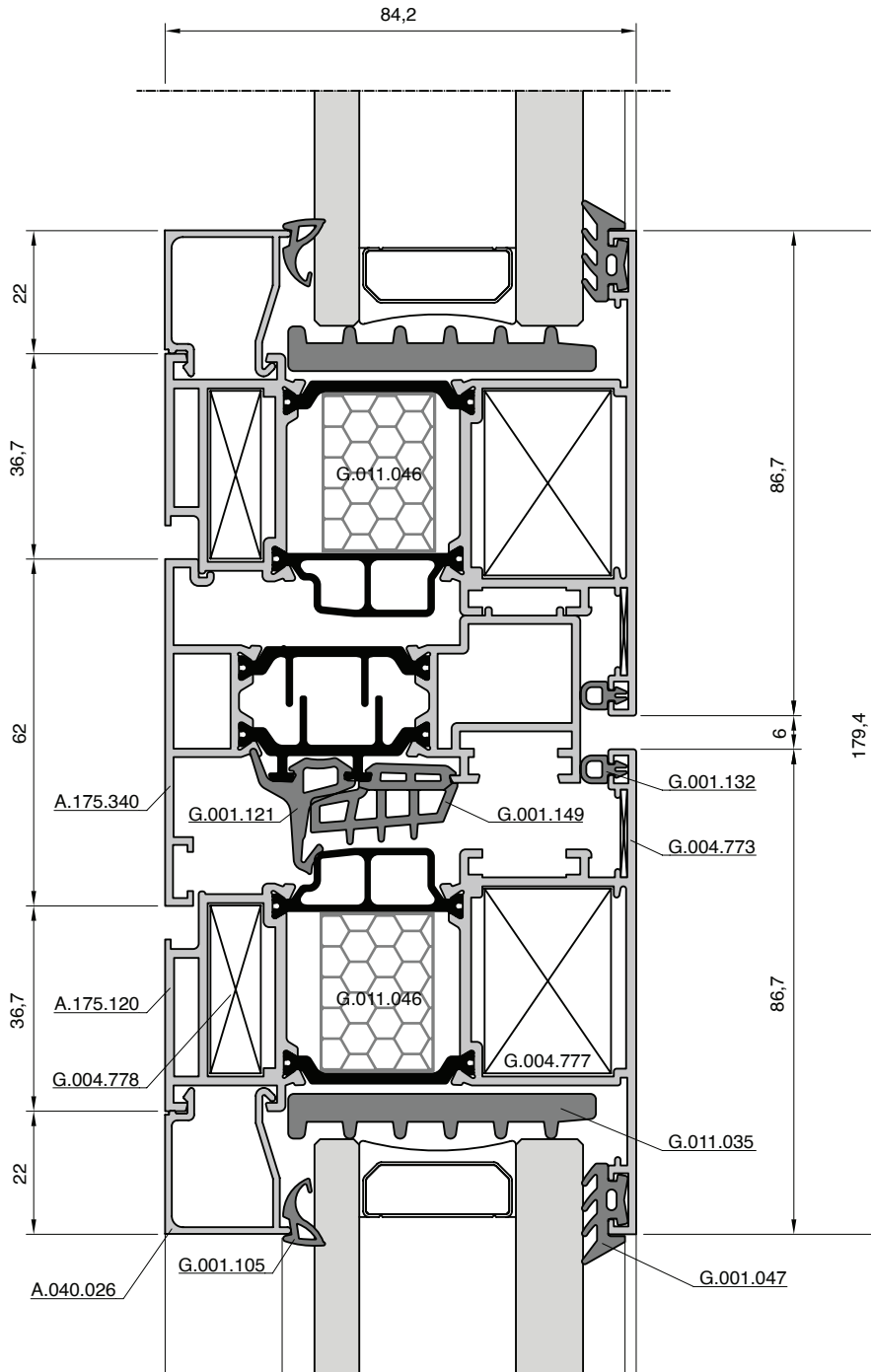
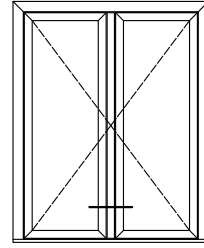

Produto  
6

Características Técnicas  
8

Perfis  
18

Seções  
46

Tipologias Construtivas  
68

Instruções Fabrico  
136

Instruções Montagem  
144

Acessórios  
152

# SECCÃO P PIVÔTANTE

A.175

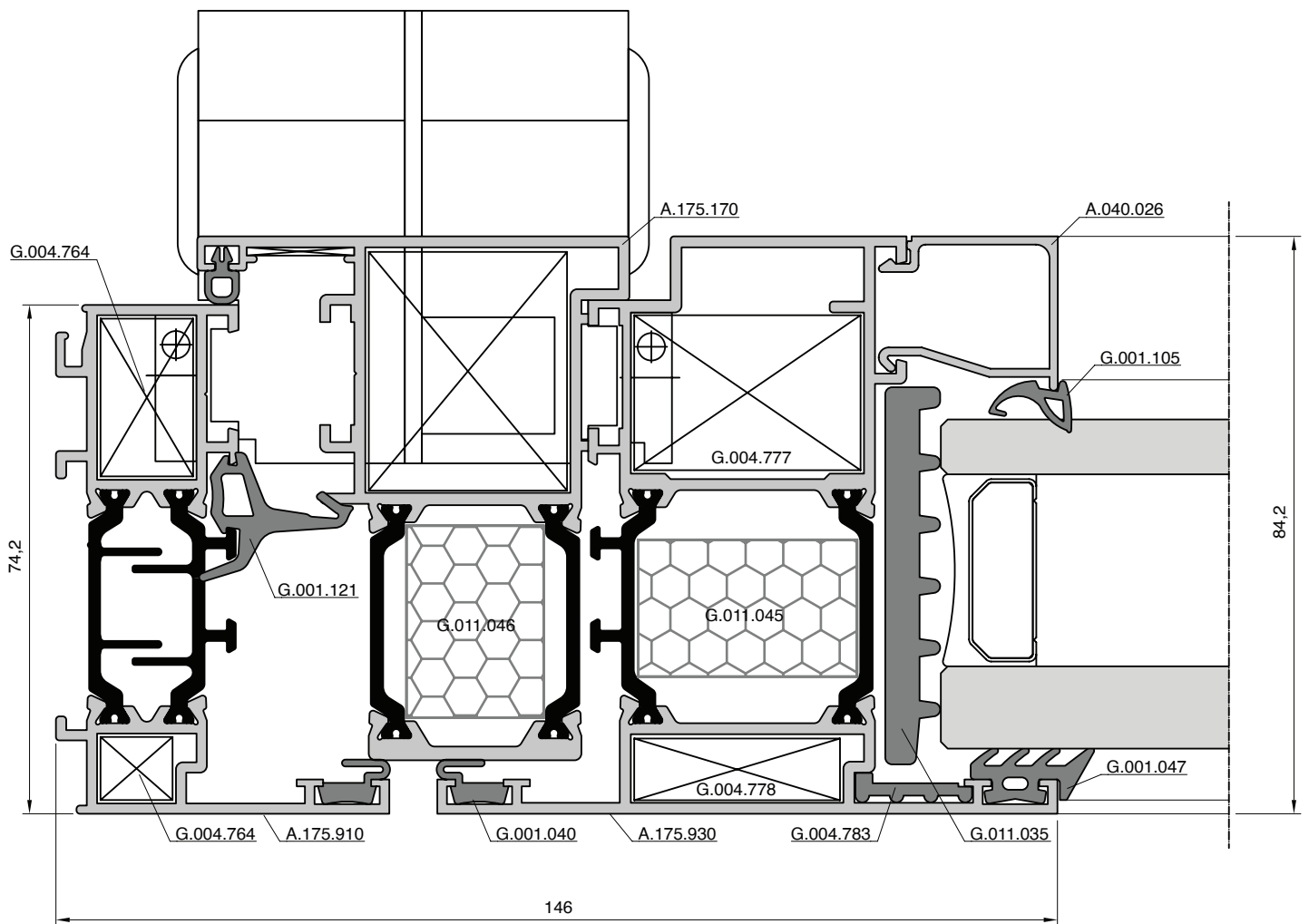
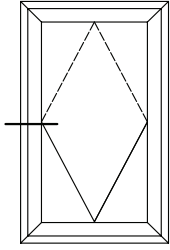

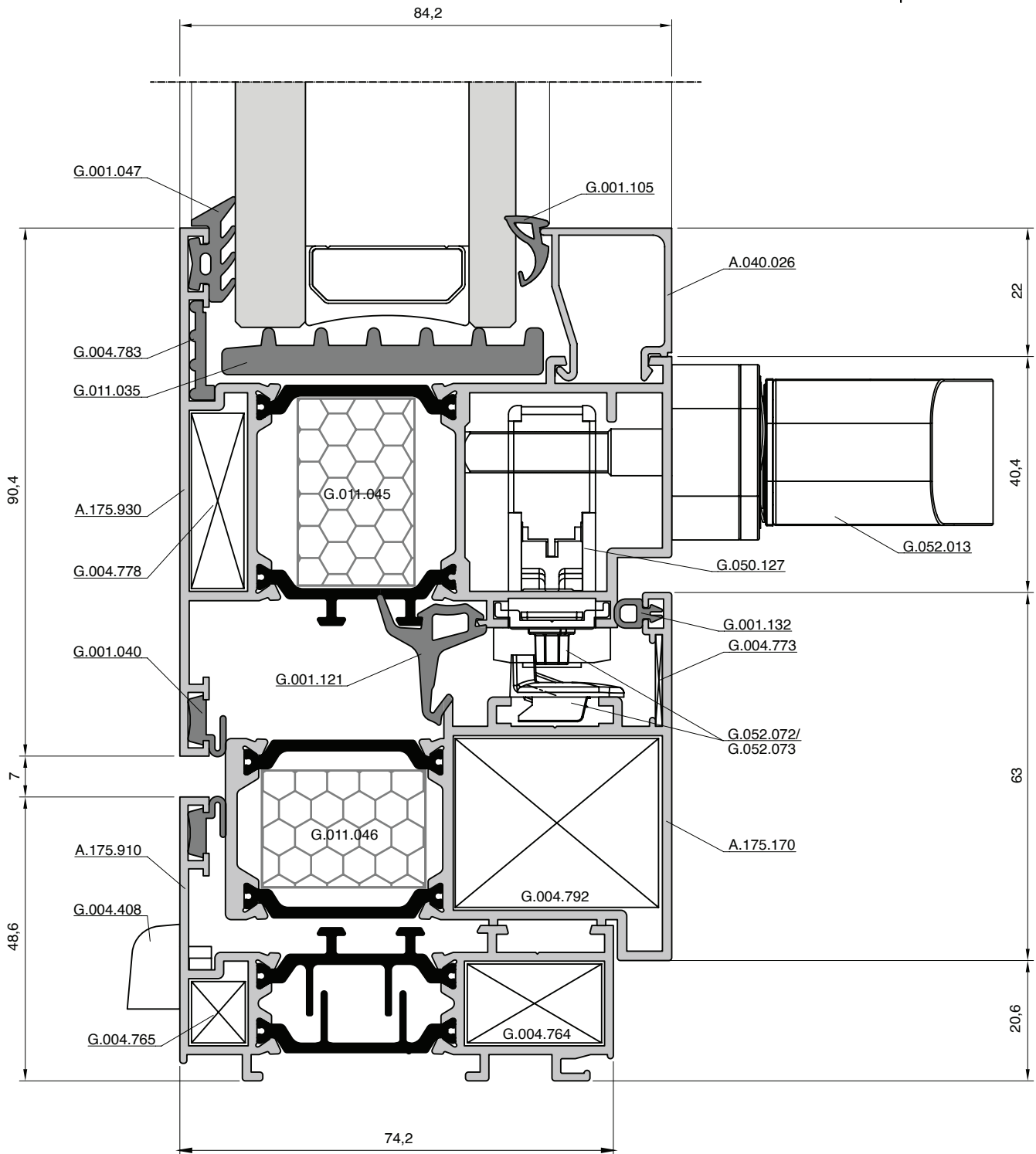
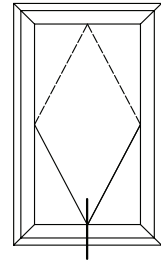

Produto  
6

Características Técnicas  
8

Perfis  
18

Seções  
46

Tipologias Construtivas  
68

Instruções Fabrico  
136

Instruções Montagem  
144

Acessórios  
152

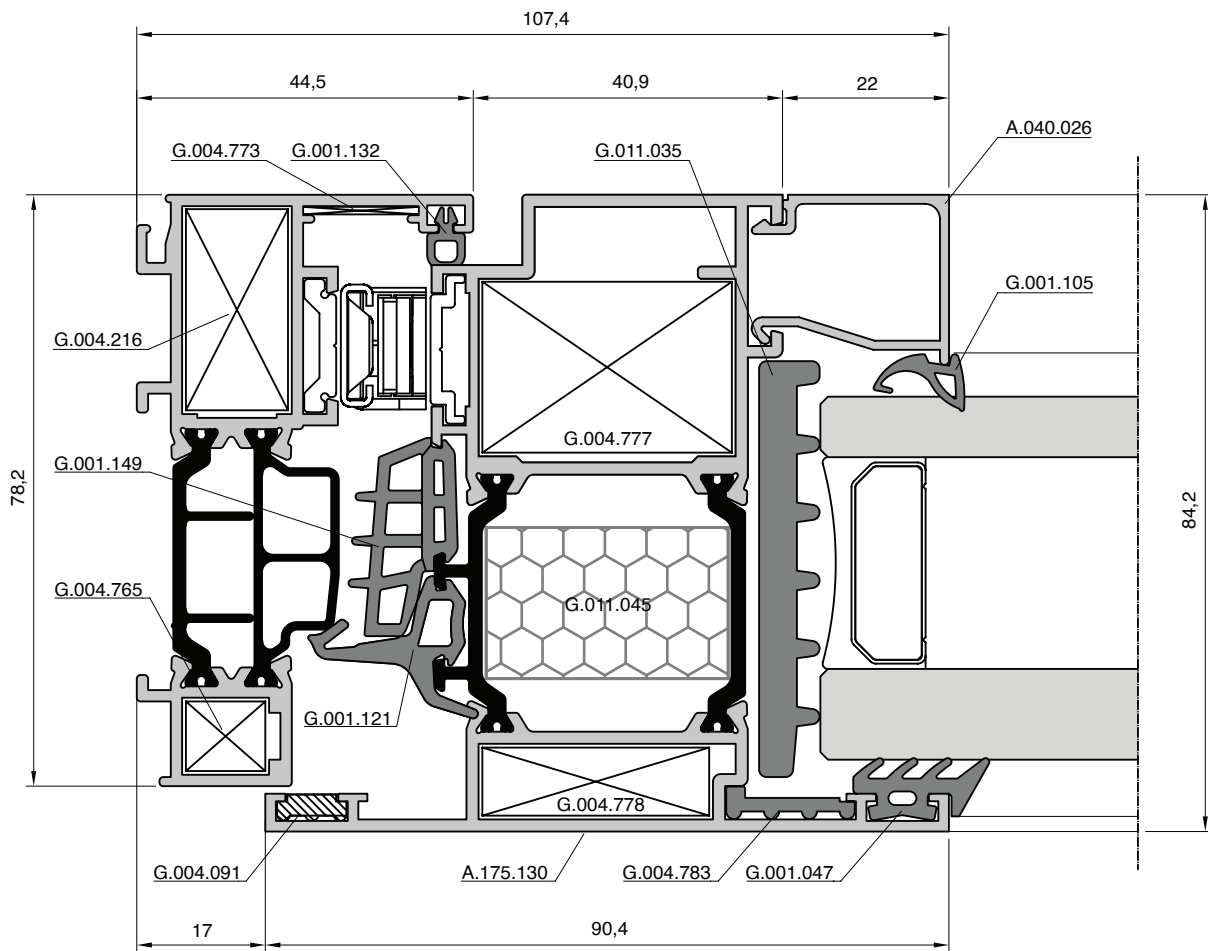
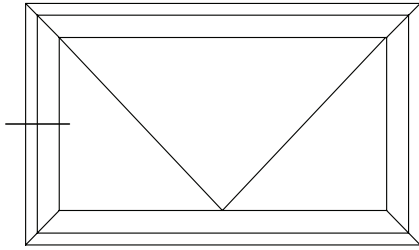

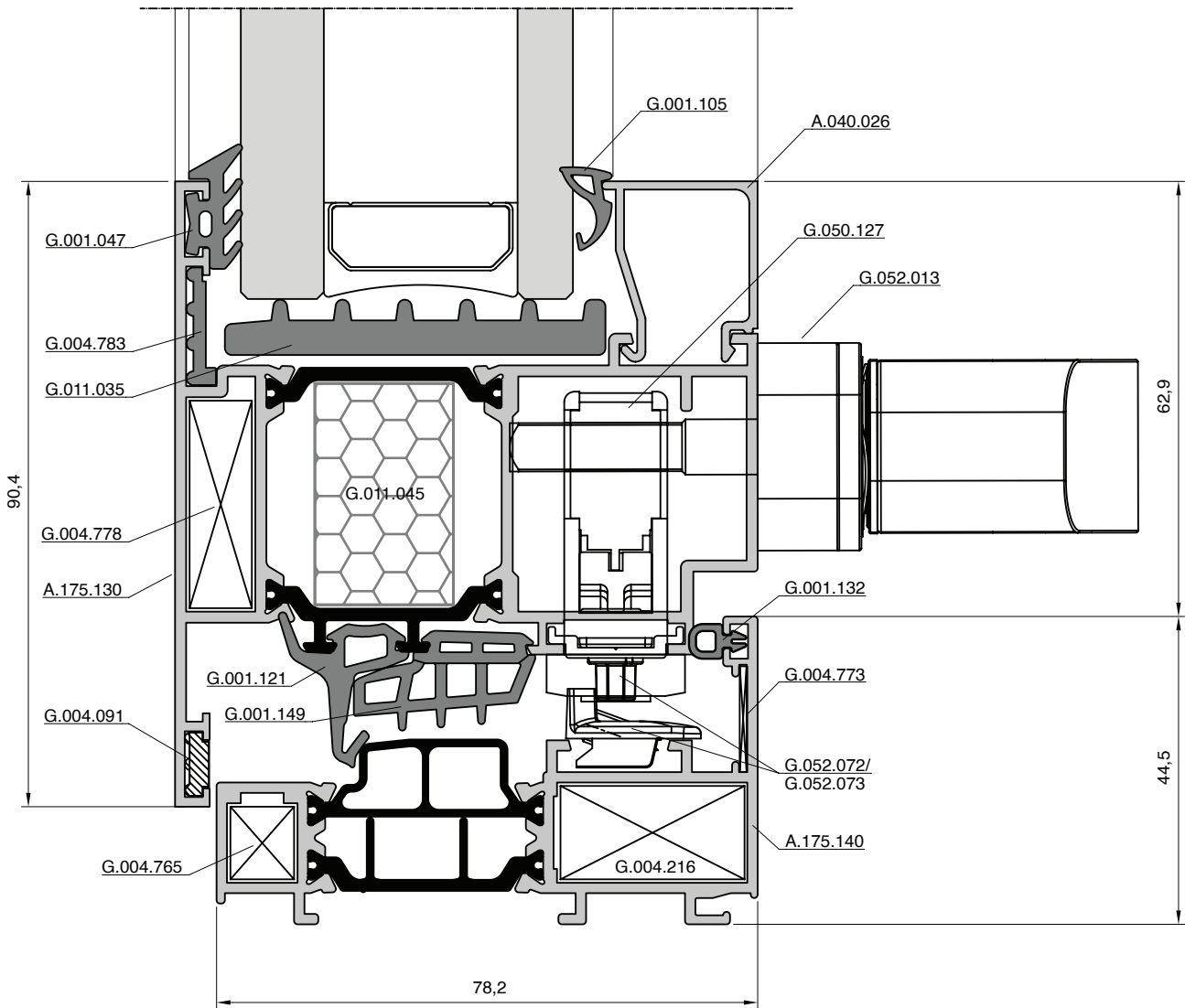
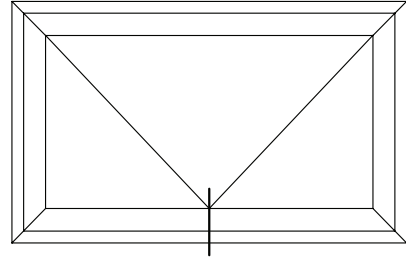

Produto  
6

Características Técnicas  
8

Perfis  
18

Seções  
46

Tipologias Construtivas  
68

Instruções Fabrico  
136

Instruções Montagem  
144

Acessórios  
152

# SECÇÃO T SOLUÇÃO DE CANTO

A.175

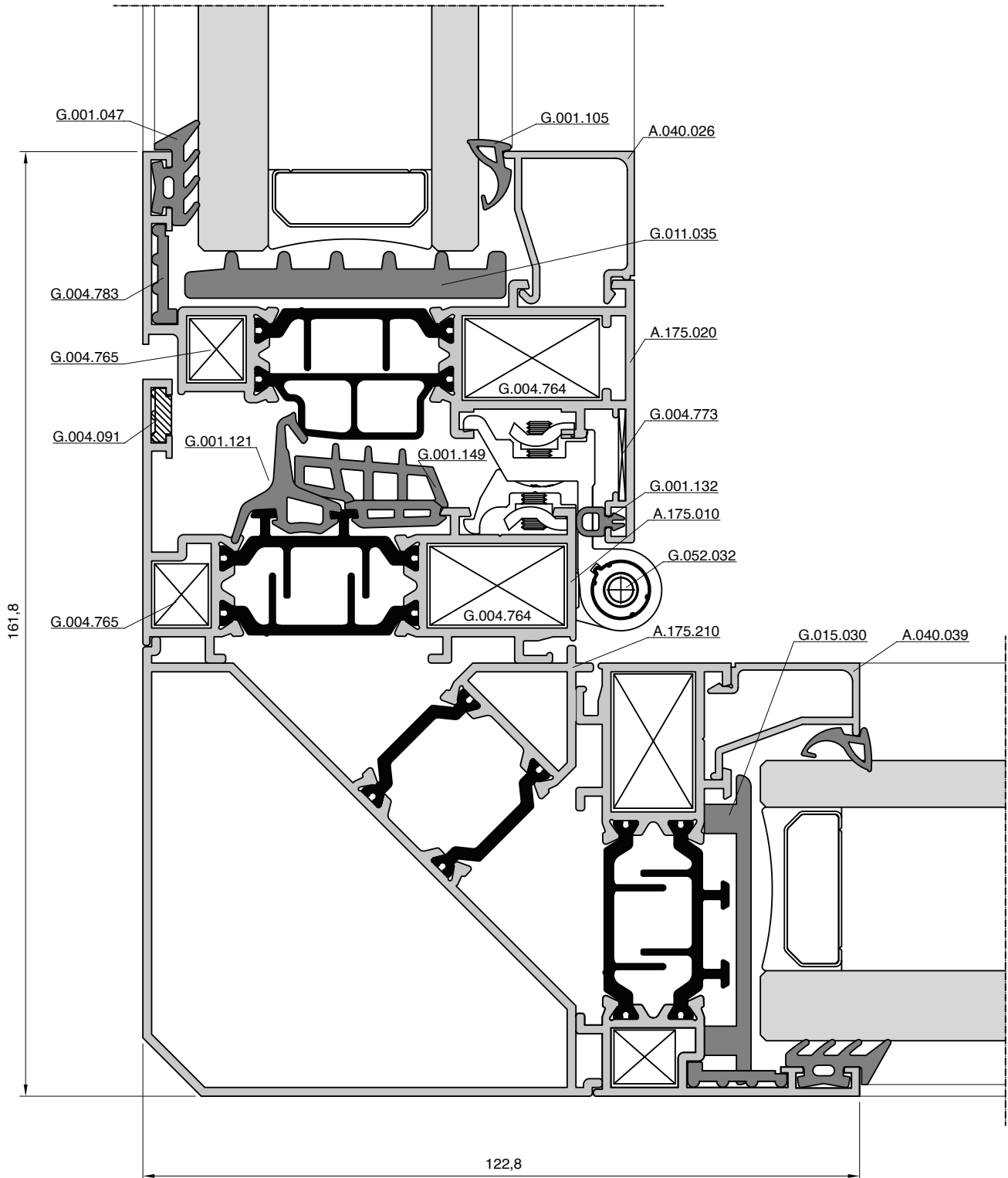
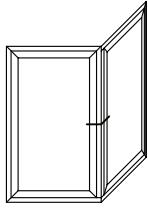



**Produto**  
6

**Características Técnicas**  
8

**Perfis**  
18

**Secções**  
46

**Tipologias Construtivas**  
68

**Instruções Fábrico**  
136

**Instruções Montagem**  
144

**Acessórios**  
152

# Extrusal<sup>®</sup>

Alumínio com perfil humano.

 **Rua do Sacobão - Aradas**  
3810 - 454 Aveiro  
Portugal

 **www.extrusal.pt**  
tecnico.aveiro@portalex.eu  
(+351) 234 378 900

